

RATIONAL ACOUSTICS

# Smart LE

USER GUIDE

*RELEASE 9.1*





Rational Acoustics Smart LE User Guide Copyright Notice

Copyright ©2022, Rational Acoustics LLC. All rights reserved. Except as permitted by the United States Copyright Act of 1976, no part of this document may be reproduced or distributed in any form whatsoever or stored in any publicly accessible database or retrieval system without prior written permission from Rational Acoustics, LLC. Smart, SmartLive, Rational Acoustics and the Rational Acoustics logo are registered trademarks of Rational Acoustics, LLC. All other trademarks mentioned in this document are the property of their respective owners.

For information contact:

Rational Acoustics LLC  
32 Crabtree Lane  
Woodstock CT 06281 USA  
Telephone: (+1) 860 928-7828  
Email: [info@rationalacoustics.com](mailto:info@rationalacoustics.com)  
Web: <http://www.rationalacoustics.com>

## TABLE OF CONTENTS

1 - Introduction .....	7
What is Smaart?.....	7
What is this Guide? .....	7
A Note About Smaart’s Help files.....	8
Hotkey and mouse click Notation.....	8
Full Scale (dBFS) versus Full Scale.....	8
Getting Started.....	8
my.rationalacoustics.com .....	8
Installing and Activating.....	9
Basic Computer Requirements .....	9
2 – Getting Started – Navigating Smaart .....	10
Fundamental Paradigms and Technology.....	10
Smaart is a tool – you are the analyzer.....	10
Multi-Input/output, Multi-Engine.....	10
Highly Configurable.....	11
Control Priority.....	11
Welcome to Smaart – A GUI Tour.....	12
Interface Control Bars .....	12
Data / Plot Area.....	13
Menus .....	13
Clock / Broadband Level Meter .....	13
Launching Smaart.....	14
First Launch vs Subsequent Launches.....	14
Initial Configuration – Getting Input Signals.....	15
Initial Configuration – Selecting Outputs.....	17
Understanding Levels of Configuration .....	18
The Smaart v9 File Structure.....	18
Measurement Data.....	19
Configurations.....	19
Other Program Files .....	19
3 – Controlling Smaart and Viewing Data .....	20
Fundamental Concepts .....	20
Ways to Control Smaart.....	20

Linear vs Logarithmic Plot Scaling.....	20
Focus .....	23
View, Data, and Plot Controls .....	25
Plot View Controls.....	25
Plot Controls.....	27
Graph Settings.....	30
Data Controls.....	34
Banding and Smoothing .....	40
Cursor Readout .....	42
Capturing and Handling Data .....	45
The Data Bar.....	45
Capturing Data .....	46
Data Folder Structure.....	47
Data Bar Menu .....	47
Averaging Stored Data .....	49
Importing and Exporting Data.....	50
The Signal Generator.....	51
Control Area .....	51
Signal Generator Dialog .....	51
Signal Types.....	52
Skins.....	54
Input Meters.....	55
API .....	55
Advanced Settings.....	56
4 – Fundamental Measurement Concepts.....	57
Questions and Viewpoints .....	57
Signal Analysis vs System Response Analysis: Single vs Dual Channel Measurements.....	57
Time Domain vs Frequency Domain Analysis .....	58
The Measurement “Four Square” .....	59
Broadband vs Bandlimited .....	60
The Fourier Transform – The Engine That Powers the Analyzer .....	60
Time-Frequency Relationships.....	61
DFT, FFT and IFT .....	62
Complex Data.....	63

Spectrum Measurements (Single Channel) .....	63
RTA .....	63
Spectrograph.....	64
The Transfer Function (Dual Channel) .....	65
The Views of the System Response .....	65
Measurement Issues.....	71
Averaging – A Powerful Data Analysis Tool .....	74
Temporal Averaging.....	74
Spatial Averaging.....	76
Protecting the Averaging Buffer – Improving Data .....	78
Correction, Calibration, and Comparison .....	79
Microphone Correction Files .....	79
Sound Level Calibration (Only Needed for SPL Measurement).....	80
Comparing Measurements .....	81
5 – Configuring Measurement Engines.....	82
Control Bar Measurement Engine Right-Click Menu.....	82
Creating and Configuring Spectrum Engines .....	83
Measurement Settings.....	84
Display Settings.....	84
Input Settings .....	84
Creating and Configuring Transfer Function Engines .....	85
Measurement Settings.....	86
Display Settings.....	87
Input Settings .....	87
Creating and Configuring Live Averaging Engines .....	87
Live Spectrum Average .....	88
Adding and Removing Engines In the Workspace .....	88
Measurement Engine Controls .....	88
6 – Making Measurements .....	91
Working from Defaults.....	91
Input and Output Selection and Naming.....	91
Measurement Setup .....	91
Signal Tap Points.....	92
Gain Structure and Signals Check .....	92

Microphone Correction Curves.....	92
Multiple Microphone Workflows.....	93
Changing Settings.....	94
Data Acquisition .....	94
Data Labeling and Organization.....	94
Coloring Averages .....	94
Sending Data to A Colleague.....	94
A Ghost In the Machine.....	95
7 – Measurement Examples.....	96
Setting EQ for a Loudspeaker.....	96
Observing Near Field vs Far Field response .....	104
Appendix A: Further Reading.....	106
Appendix B: Boundary effects.....	107
Acoustically Small Sources .....	107
Microphones Near Boundaries .....	107
Appendix C: Typical Measurement Rig Set-Up .....	109
Stereo (2x2) Audio I-O.....	109
Multi-Channel I-O.....	110
Traditional USB/FireWire Stand-Alone Interfaces .....	110
Network Audio I-O .....	110
Appendix D: Text File Format for ASCII Import.....	112

## 1 - INTRODUCTION

### WHAT IS SMAART?

Rational Acoustics Smaart® is a dual-channel, real time, FFT-based audio analyzer software application that enables you to measure and analyze the frequency content of audio signals, study the timing and response of sound systems and audio devices, and perform basic sound level measurement. Being a software application, Smaart is hardware independent and can process signals from nearly any audio device connected to your computer, which allows the flexibility to scale across a wide variety of field measurement and analysis applications.

Smaart is available in four basic versions with different functionality: Suite, RT, LE, and SPL.

- **Smaart Suite** is the flagship edition of Smaart, containing all three functional modes (Real Time, Impulse Response, and SPL).
- **Smaart RT** (“Real Time”) is Smaart’s dual-channel real time FFT analysis toolset that also includes a host of advanced functions and mathematical parameters.
- **Smaart LE** (“Light Edition”) is a streamlined version of the Real-Time toolset that offers the same core functions and input/output capability as RT, without access to some of the more advanced functions and measurement parameters.
- **Smaart SPL** contains Smaart’s full sound pressure level monitoring, logging and reporting tools.

**Smaart LE** is designed to provide all the essential tools and functions for modern real time sound system measurement and alignment workflows while maintaining an approachable and intuitive interface. It is closely aligned with the Rational Acoustics training curriculum and school of thought on sound system measurement, and as such can be considered the “everything you need and nothing you don’t” version of Smaart.

### WHAT IS THIS GUIDE?

This guide is a practical introduction to configuring and operating Smaart LE. Our goals are to provide a comprehensive explanation of the program and its features and operation, along with a brief survey of some of the core concepts related to acoustic measurement and analysis. For anyone interested in learning more about sound system engineering or acoustic measurement, a list of additional resources is provided in the appendices.

We begin with the assumption that the reader has a basic understanding of professional audio equipment, engineering practices, and signal and system analysis, and focus on the configuration and navigation of Smaart. Users familiar with Smaart v8, Smaart Di v2, or previous versions will be able to quickly get up and running with Smaart LE. For those seeking to gain familiarity with the Smaart ecosystem and/or measurement concepts in general, an exploration of fundamental concepts and terminology can be found starting in Chapter 4.

As this user guide is an electronic document, in addition to the Table of Contents, the user can use a full text search to quickly locate any keywords of interests. In most PDF readers, the search function can be activated by using the keyboard shortcut [Ctrl/Cmd] + [F].

---

## A NOTE ABOUT SMAART'S HELP FILES

Smaart includes a comprehensive set of help files, which can be accessed from within the program by clicking *Help* in the program's menu bar (found at the top of the main program window on Windows operating systems, or across the top of the display on macOS computers). These helpfiles contain a concise reference for features and functions within Smaart and are intended as a companion to this user guide. The helpfiles and this user guide contain much of the same material but organized in different ways. While this guide attempts to group information conceptually, the helpfiles are organized to be in parallel with Smaart's user interface, to allow you to quickly "drill down" through menus, dialogs, and on-screen controls to find what you are looking for.

---

## HOTKEY AND MOUSE CLICK NOTATION

Since Smaart LE runs on both Windows and macOS, there are some minor differences in keyboard commands between the two versions. Specifically, the Control [Ctrl] key in Windows serves the same purpose as the Command [Cmd] key on macOS, and the [Alt] key in Windows is equivalent to the [Option] key on macOS.

In this document, we'll write the names of keys used for keyboard shortcuts ("hotkeys") in brackets. In cases where Mac and Windows have different key names, both names will appear inside the brackets separated by a slash. For example, [Ctrl/Cmd] means the [Ctrl] key on Windows or the [Cmd] key on macOS. As regards the mouse, left-click on Windows is a regular mouse click on macOS. A right-click for Windows users means [Ctrl] + click on macOS.

---

## FULL SCALE (DBFS) VERSUS FULL SCALE

There exist two competing references for decibels in digital audio signals. Once convention references dBFS to the largest possible amplitude value in a digital system, such that 0 dBFS denotes the maximum possible digital amplitude value. We refer to this as "normalized Full Scale."

The second convention, preferred by the Audio Engineering Society (AES), references 0 dBFS to the *RMS* value of a full-scale peak-to-peak sinewave (i.e. 0.7071 normalized Full Scale, rather than 1.0). We will call this "AES Full Scale."

In Smaart, Full Scale decibel values are always referenced to normalized full scale, meaning that the RMS level of a full-scale digital sinewave is -3.01 dBFS.

## GETTING STARTED

To get started, you will need to install Smaart onto your computer and license the installation.

---

## MY.RATIONALACOUSTICS.COM

The online account portal at [my.rationalacoustics.com](https://my.rationalacoustics.com) is the centralized location by which Smaart software licensing is managed. If you don't already have an account, you should create one, and then you can register your new Smaart license by clicking the appropriately named "Register a new Smaart License" button on the Account Details page.

You can also manage existing licenses, upgrade licenses and add installs, and download installers for macOS and Windows computers. Click the *Downloads* tab in the navigation bar to access downloadable installers for



all the versions of Smaart that are registered to your account, both for Windows and macOS. Take care to download the appropriate version.

---

## INSTALLING AND ACTIVATING

Once the installer is downloaded, run it and follow the prompts. Smaart licenses are either Perpetual or Subscription. Perpetual licenses can be activated online or offline, while Subscription licenses can only be activated online. More detailed information about the activation process can be found in the Licensing Guides that appear in the Documentation section of the support portal at RationalAcoustics.com. If you require assistance with the licensing process, please contact Rational Acoustics support.

---

### ONLINE ACTIVATION (PERPETUAL OR SUBSCRIPTION)

Following installation, the first time you run Smaart, you will be presented with an activation screen asking you to select your license type – perpetual or subscription. The next page will ask for your license code, followed by your my.rationalacoustics.com account information. The final screen will ask for your name and email address, as well as a Computer Name identifier of your choice. Then click *Activate* to activate your license.

---

### OFFLINE ACTIVATION (PERPETUAL ONLY)

If you need to activate Smaart on a computer that is not connected to the Internet, you can manually register the Smaart Machine ID from within your account at my.rationalacoustics.com. Open Smaart on the computer that is not connected to the Internet and note that the Machine ID will be displayed on the Offline Activation screen (clicking the Machine ID will copy it to your clipboard).

From any device that is connected the Internet, open a web browser, navigate to <https://my.rationalacoustics.com>, and log in to your license management account. Once logged in, you'll see a list of all Smaart licenses registered to your account. Click on your Smaart LE license code and you will be brought to its Details page.

Click the link next to “If you do not have an internet connection” under Download and Install. Within the form it brings up, enter your Machine ID, the name and e-mail address you want to associate with this installation, and a friendly name to identify the computer. There is also a field for a Block Code, however you can ignore this unless you are reactivating an installation on a computer that was previously deactivated. When you finish entering the required information, click the Submit button to get your Activation Code. Go back to Smaart on your offline machine, enter the Activation Code into the “Offline Activation” section, and click the Activate button. If the code is correct, you will see a success message.

---

## BASIC COMPUTER REQUIREMENTS

You can find the most up-to-date minimum system requirements for Smaart v9 on our website at rationalacoustics.com. The minimum system requirements for Smaart v9 have changed from v8, and may be updated as new hardware, operating systems and program features become available. These minimum requirements are established to ensure reasonable performance when default settings are used. You should consider a more powerful computer if you plan to use large FFT sizes or run many measurements at the same time.

## 2 – GETTING STARTED – NAVIGATING SMAART

Now that you have Smaart installed, activated, and ready for use, let's take a brief look at some of the fundamental concepts and features that you'll want to be familiar with as you work with the software.

### FUNDAMENTAL PARADIGMS AND TECHNOLOGY

---

#### SMAART IS A TOOL – YOU ARE THE ANALYZER

Perhaps the most important thing to keep in mind when working with Smaart is that, conceptually speaking, Smaart is a *measurement tool*. Taking a measurement is asking a question – and Smaart can perform a wide variety of measurements to answer different questions. Therefore, using Smaart effectively requires you to be thinking about *what question you're asking*. Like all measurement tools, which exist to display information to the user, Smaart displays information about the signals we send it.

Deciding what signals or microphone positions to feed Smaart is part of the decision-making process that allows us to gather repeatable, actionable measurement data that will help form a solid basis for our decisions. But we must keep in mind – *we* make the decisions. Smaart is just a tool we use to make our decisions more informed. In other words – Smaart is a tool, *you* are the analyzer.

---

#### MULTI-INPUT/OUTPUT, MULTI-ENGINE

Since Smaart's core function is to display information about the signals it receives, it is important to understand how Smaart acquires those signals. Smaart's multi-device, multi-input capabilities mean that the analyzer can access any number of signals at once, from multiple audio devices at once. There are no software-imposed limitations on the number of signals or devices – you are limited only by what your computer and hardware can accommodate. Though there are sometimes limitations imposed by the computer's operating system and/or device drivers (for example, a single ASIO-based device at once on a Windows computer), Smaart should be able to access signals from any audio device that is connected to and recognized by your operating system. Likewise, Smaart's signal generator can output to any connected devices.

Once input devices and channels are configured, they can be selected to feed as many spectrum and transfer function measurement engines as you desire. Each measurement engine can have its own unique configuration, which allows you to configure multiple engines to generate different data from the same input signal(s).

---

#### LIVE AND STORED MEASUREMENTS

At any time, the data produced by a measurement engine can be captured and stored into Smaart's data library, which is found in the Data Bar along the left side of the main window. Measurement data is always captured directly at full resolution, regardless of the current banding or smoothing settings, so that those parameters can be adjusted later without any changes to the raw underlying measurement data. Smaart allows you to hide and show both live and stored measurement data and work with both at once in the same plot.

---

### GRANULARITY OF CONTROL

Smaart utilizes a tiered system for control over measurement engine parameters – a global control sets the overall behavior of a parameter, and individual engines can be exempted from global and set individually. For example, you can set the global averaging for all Spectrum engines using the dropdown in the control bar, and you can also exempt individual engines from following the global setting and give them an individual averaging setting. This would be helpful for investigating the differences between averaging settings, or for providing two views of the same signal for additional context.

---

### HIGHLY CONFIGURABLE

Smaart’s default settings have been carefully chosen to allow you to start taking actionable measurements without the need for extensive setup or configuration. However, Smaart can be configured to best suit a given application. Central to the successful use of Smaart is your ability to view the data in a way that is useful – that is, knowing how to configure Smaart to show you what you need to see to answer the questions you’re asking. Although Smaart LE has some measurement parameters pre-selected, there is still a high level of configurability to lay out the program interface, data, and views as you desire.

Smaart is designed to allow the program configuration to be easily and actively modified “on the fly” as you work. The on-screen controls, hotkeys and view presets allow you to quickly change window layouts and plot views as you go. Preferred and commonly used configurations can be easily stored and recalled, as well as view presets and plot zooms. Taken together, these features offer the flexibility to help you acquire the necessary data and display it in a helpful way as efficiently as possible.

---

### CONTROL PRIORITY

Controls in Smaart are arranged in order of priority. Controls that are typically adjusted frequently throughout a measurement session, such as smoothing and averaging, are easily accessible via the top level of the interface, whereas controls and settings found within Smaart’s Options menus might be accessed once per measurement session or less. In other words – the more clicks it takes to get to a setting, the less likely it is that you need to adjust it frequently.

## WELCOME TO SMAART – A GUI TOUR

In this section, we'll help you familiarize yourself with the layout of Smart's graphical user interface (GUI) by taking a quick tour through the major elements.

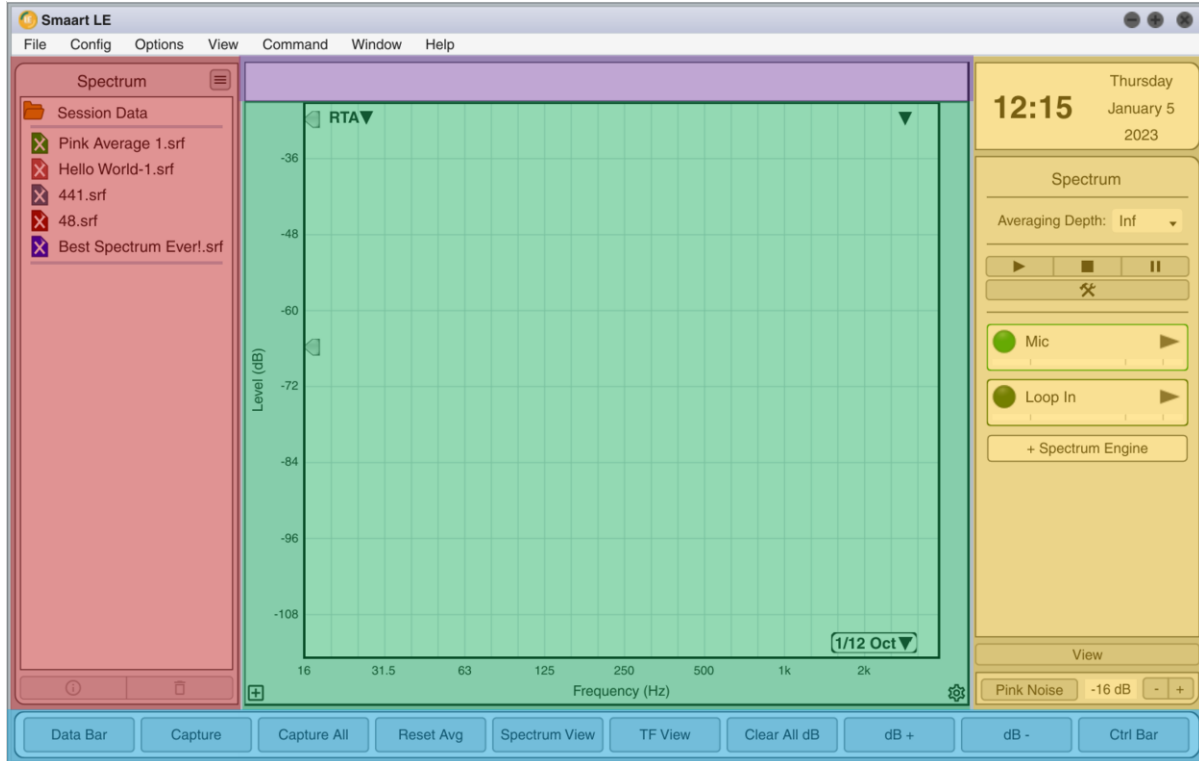

Figure 1 - Smart LE interface overview. Data Bar (red), Control Bar (gold), Graph Area (green), Command Bar (blue) and Cursor Readout (purple)

## INTERFACE CONTROL BARS

Smart LE's main program window consists of a data display area in the center framed by control bars on three sides. Taken together, these bars house the major interface elements via which Smart is operated.

### DATA LIBRARY

Along the left side of the program window is the Data Library, which is home to all stored measurement data. When a Spectrum type plot (RTA or Spectrograph) has focus, the Data Library shows captured Spectrum data. Likewise, when a Magnitude or Phase plot has focus, the Data Library displays shows saved Transfer Function measurement data. The Data Library is a live view of the stored data files in your computer's Documents folder, inside the Smart LE\Data subdirectory.

### CONTROL BAR

The Control Bar is found along the right side of the main program window. The Control Bar, true to its name, houses measurement engine controls. At the top of the Control Bar is a docked level meter which doubles as a clock. At the bottom of the Control Bar is the Signal Generator, as well as a button to open the Views flyout.

Like the Data Bar, the Control Bar shows Spectrum engines and controls when a spectrum-type plot has focus, and Transfer Function engines and controls when a transfer function-type plot is selected.

---

## COMMAND BAR

The Command Bar spans the bottom of the main program window and contains 10 Command Buttons. Each Command Button can be user-assigned to any function or command in Smaart that has a keyboard shortcut associated with it by opening the Config menu and choosing *Command Bar Config*.

---

## DATA / PLOT AREA

The plot area inhabits the center of the program window and is the majority shareholder of screen real estate in Smaart. This is where live and stored measurement data is displayed. The plot area can be a single graph, or divided into two. When a Transfer Function graph type (*Magnitude* or *Phase*) is visible, an additional *Live IR* plot is shown at the top of the plot area by default.

---

## PLOTS

Plots are the central focus of Smaart – they are where live and stored measurement data is displayed and manipulated. All plots in Smaart follow the same convention for identification and navigation: the upper left corner of each plot shows the type of graph (*RTA*, *Spectrogram*, *Magnitude*, *Phase*, etc). Click the plot label text or the arrow next to it to open the droplist and change the plot to a different type.

Likewise, all plots in Smaart always display the name of the currently displayed measurement data. If more than one measurement is displayed in the plot, the name of the measurement at the top of the z order will be displayed. Click the data name text or the arrow next to it to open the Plot Legend, which allows you to view and control all measurement data currently displayed in that plot.

---

## CURSOR READOUT AREA

Across the very top of the plot area is the Cursor Readout Area. The cursor readout always displays precise information about the data under the cursor location (amplitude, frequency, or time units depending on the data type). The cursor readout can also display *Wavelength* or musical *Note ID* on frequency-domain graphs, and distance units on time-domain graphs, by enabling these in the *Cursor* tab of the *Options > Preferences* dialog. The cursor has a number of helpful functions and options, see *Cursor Readout* on page 42.

---

## MENUS

Smaart's main menus span the top of the program window on Windows, and the top of the display on macOS. The top level menus collect functions into general categories (*File*, *Config*, *Options*, *View*, *Command*, *Window*, and *Help*). In this guide, carets will indicate the navigation path through the menus and any submenus. For example, *Options > Measurement Settings > Transfer Function* means to open the *Options* menu, choose the *Measurement Settings* entry, and then select the *Transfer Function*.

---

## CLOCK / BROADBAND LEVEL METER

At the top of the Control Bar is a broadband level meter. The dropdown in the upper right allows you to select an input to view on the meter. The dropdown below that allows you to select the sound level metric, although

you are only able to view sound level information for inputs that have been calibrated for SPL. The full scale digital level (dBFS) can be viewed for all inputs.

The broadband meter can also be swapped for a clock, if desired, by right-clicking the meter and choosing *Toggle Clock*, or by pressing the hotkey [K].

## LAUNCHING SMART

### FIRST LAUNCH VS SUBSEQUENT LAUNCHES

The first time you launch Smart LE, it will display a message that no measurement engines are configured and invite you to start the process by selecting input sources. When you click *OK*, Smart will display the IO Config dialog.

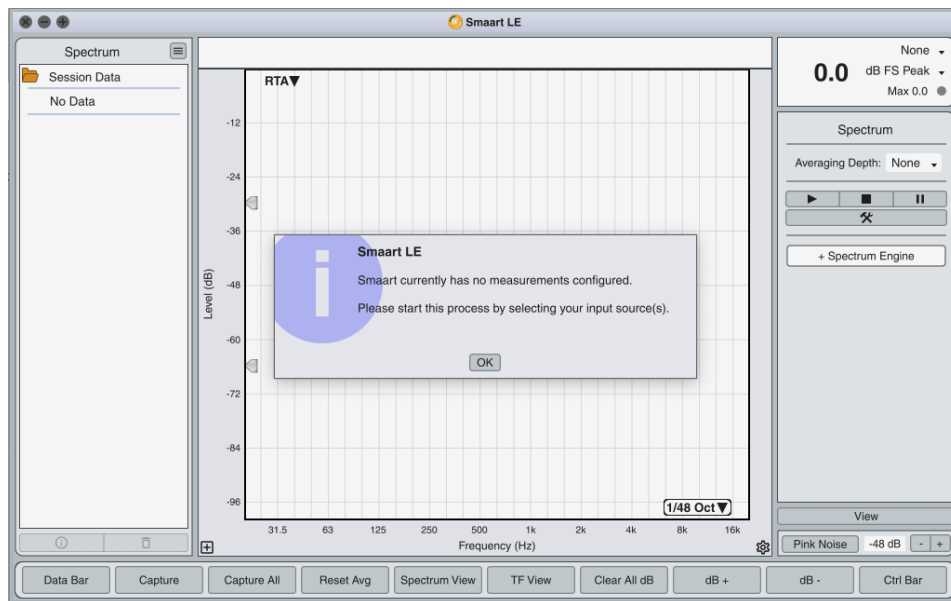

Figure 2 - The First Launch dialog, informing you that no measurements are configured and that you should start by selecting input signals.

On subsequent launches, Smart will offer you a choice. Choose “Continue with the current configuration” to pick up where you left off last time. Choose “Create a new Configuration” to keep your existing settings but choose new inputs and create new measurement engines. Choosing “Select a previous configuration” will allow you to load a configuration you’ve saved previously.

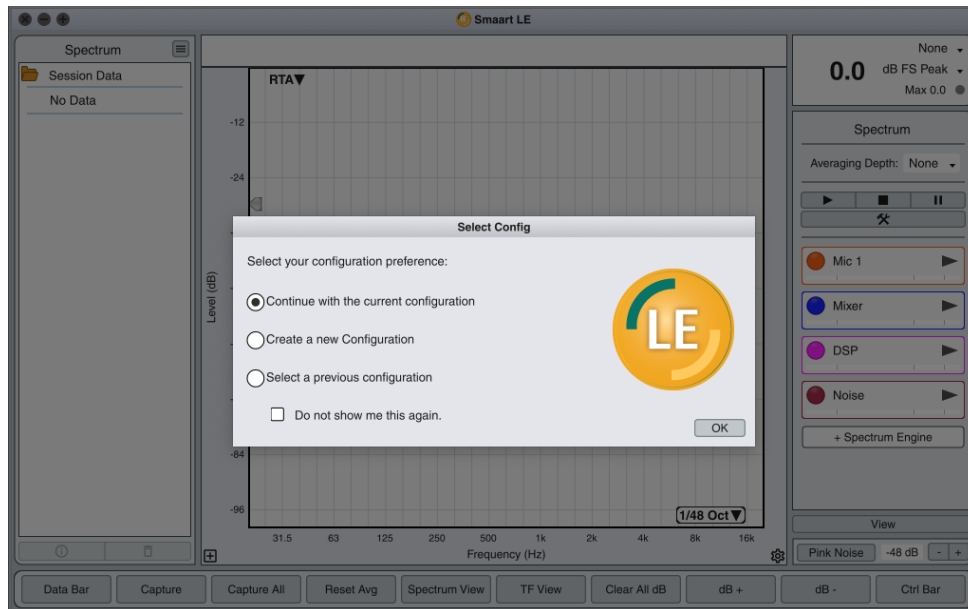

Figure 3 - the Select Config dialog that appears on subsequent launches

Note that at any time, you can completely restore Smart to its default settings by choosing *Manage Configurations* from the Config menu and clicking the *Restore Defaults* button.

## INITIAL CONFIGURATION – GETTING INPUT SIGNALS

In order to start our work, we have to get input signals into Smart – we do this by selecting which input device(s) we wish to use, and which channels on those devices. This is done in the IO Config dialog, which Smart will automatically display on first launch.

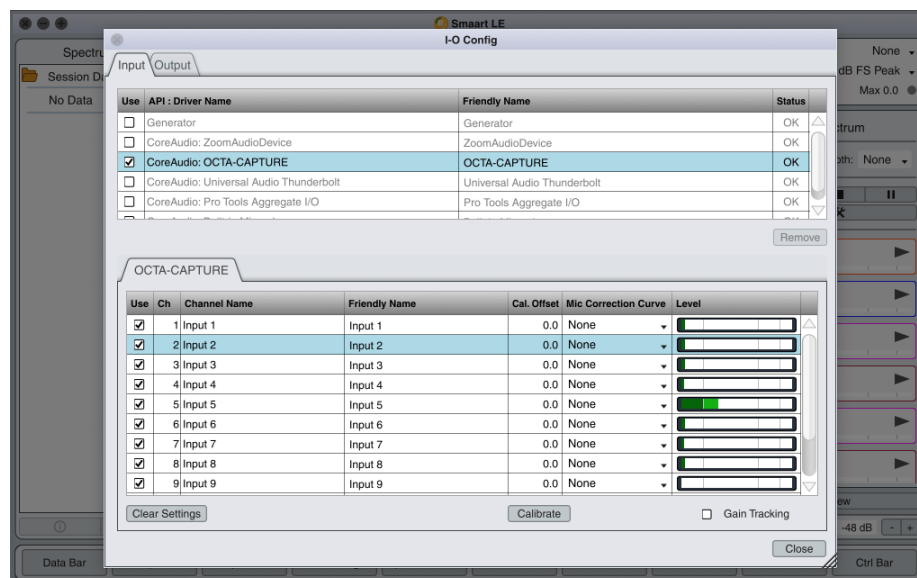

Figure 4 - the Input tab of the I-O Config dialog

The IO Config dialog has two tabs, *Input* and *Output*. Of course, most IO devices have both inputs and outputs, but the operating system – and therefore, Smaart – can treat them separately. At the top of the Input tab is the devices table, which lists all audio devices that your operating system recognizes. While previous versions of Smaart required IO devices to be connected and recognized by the operating system before launching the software, Smaart v9 can dynamically detect IO devices connected at any time. Once you connect your device, it should populate in the top pane of IO Config dialogue after a short delay, provided the proper drivers are installed.

To select a device for use in Smaart, click its check box in the *Use* column. The *API: Driver Name* column lists the name that the audio device (or its driver) reports to the operating system. On macOS, all devices will use CoreAudio. Windows machines may have ASIO and Wave API devices, and some devices may appear as both types.

Note: If you have both Wave and ASIO drivers installed for an IO device with more than two channels, it will typically show up as a single ASIO device, and multiple Wave devices since the Wave API only supports two input channels per device.

In the *Friendly Name* column, you can assign an alternative name to a device if you choose – remember to press the [Enter] key after typing the name to apply your change.

The *Status* column indicates either *OK* or *N/C* for each device. *OK* means that Smaart was able to successfully connect to the device and it is ready for use, while *N/C* means “not connected”. *N/C* can mean *really* not connected – Smaart remembers the device was connected previously, but it is no longer present – or it can indicate some hardware or software problem prevented Smaart from communicating with the device. This could be a device driver issue, a loose cable, or the device needs to be restarted. You can remove an *N/C* device by selecting it in the list and clicking the *Remove* button to the bottom right of the devices table.

Enabling a device for use in the devices table will create a tab for it below the device table. The Input Channels table has 7 columns, the last of which is a live signal input meter for each input.

The check boxes in the *Use* column allow you to select the inputs you want to use in Smaart and ignore the rest. Note: clicking directly on the word *Use* in the column header will quickly select / deselect all inputs at once. The *Ch* column lists the channels by number, and *Channel Name* lists the driver-reported channel name for each.

You can assign a *Friendly Name* for each channel to help you identify it when you see it elsewhere within Smaart – make sure to press the [Enter] key to set the name after you’re done typing and move down to the next channel on the list.

The *Cal Offset* column indicates the calibration offset for sound level measurements. A calibration offset of zero means the input is not calibrated for sound level measurements. Once the input has been calibrated, the *Cal Offset* value displayed corresponds to the acoustic level at the microphone that will bring that input’s convertor to 0 dBFS. For more information, see Sound Level Calibration (Only Needed for SPL Measurement) on page 80.

The *Mic Correction Curve* selector allows you to assign microphone correction curves to input channels if desired. For more information on importing microphone correction curves, refer to Microphone Correction Files on page 79.



Below the Input Channels table is a *Clear Settings* button which will reset the device's configuration by clearing out all calibration offsets, microphone correction curves, and friendly names. To the right, the *Calibrate* button opens the *Amplitude Calibration* dialog and defaults its selection to the currently selected input.

## INITIAL CONFIGURATION – SELECTING OUTPUTS

The *Output* tab of the *I/O Config* dialog looks and operates much like the *Input* tab. To select a device for use in Smart, click its check box in the *Use* column. In the *Friendly Name* column, you can assign an alternative name to a device if you choose – remember to press the [Enter] key after typing the name to apply your change.

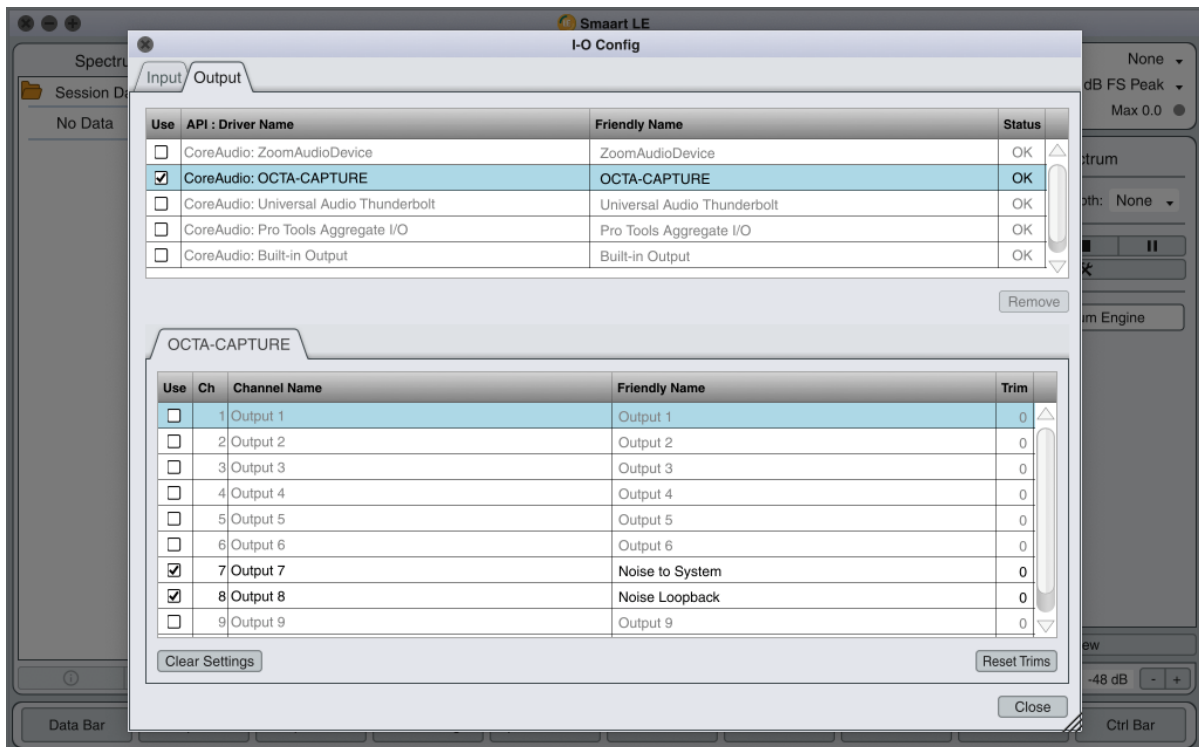

Figure 5 - the Output tab of the I-O Config dialog

Selecting an output device for use creates a tab for it below in the device table. The device's output channels are displayed in the table, and you can select any / all outputs you wish to use by checking the *Use* box for each. When the Signal Generator is running, it will route signal to all selected outputs on all devices you have selected for use. See The Signal Generator on page 51. You can assign each output channel a friendly name to help you keep things organized. Make sure to press [Enter] when you're done typing to set the name.

The *Trim* column allows you to apply attenuation individually to each selected output channel if desired. Only negative values are allowed – make sure to press [Enter] to set the change.

## UNDERSTANDING LEVELS OF CONFIGURATION

Smart has several hierarchical levels of Configuration. In the *Config* menu, the *Manage Configurations* dialog allows you to store and recall the entire program state, including IO Config, Measurement Config, and all settings and options.

There are multiple lower levels of configuration within Smart that deal with specific segments of the program. *Input Config* deals solely with input devices, channels, mic correction files and calibration offsets. *Output Config* addresses output devices, channels, and trims. *Measurement Config* includes all configured Spectrum and Transfer Function engines, *SPL Config* addresses meter display colors and Leq time and weighting, and *Command Bar Config* dictates which functions are assigned to the Command Bar across the bottom of the interface. All these items are accessible via the *Config* menu, and are collectively stored, recalled, and reset via the *Manage Configurations* dialog.

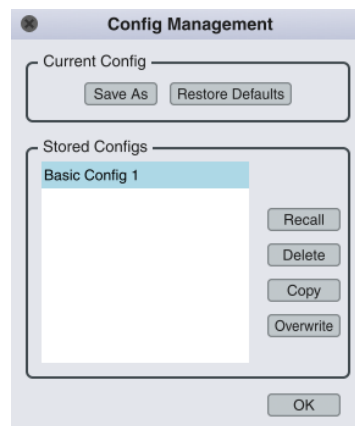

Figure 6 - the Config Management dialog

The *Manage Configurations* dialog, accessible from the *Config* menu, will allow you to save the current configuration at any time by clicking *Save As*, entering the name for the configuration, and clicking *OK*. The *Restore Defaults* button will completely restore Smart to its default state, including all configurations and settings.

Choose a stored configuration from the list and click *Recall*, and confirm with *Yes* to restore it. Use the *Delete* button to delete a stored configuration, *Copy* to duplicate it, and *Overwrite* to update the stored configuration with the current program configuration.

## THE SMART V9 FILE STRUCTURE

Smart stores all its captured measurement data and configuration data in your computer's Documents directory, in a folder called Smart LE. Inside the Smart LE folder are several subfolders, including the Config folder, which houses Smart's config data and any saved configurations, and the Data folder, where saved measurement data is kept.

---

## MEASUREMENT DATA

Smaart LE produces two main types of stored measurement data - .srf files are saved Spectrum measurement data, and .trf files are saved Transfer Function measurement data. Inside the Documents\Smaart LE\Data folder, you will find folders labeled Spectrum and Transfer Function which hold captured .srf and .trf data, respectively. The Data Bar within Smaart is a “live view” of these two folders, so renaming or deleting a saved measurement inside the Data Bar will do so inside the Data folder as well. The converse is also true. If Smaart doesn’t automatically update to reflect changes to stored data you’ve made via your computer’s file browser, you can click the three line (hamburger) menu in the data bar and select *Refresh Data Library*.

---

## CONFIGURATIONS

Stored configurations are kept in the Documents\Smaart LE\Config folder, along with Smaart’s current running configuration, which is stored in the SmaartConfig.xml file. Deleting this file is the equivalent of using the *Manage Configurations* dialog to reset Smaart to defaults and is useful in the case of unexpected behavior or as directed by Rational Acoustics support.

Stored configurations contain information about the total program state, including hardware-specific information, so it is not recommended to attempt to transfer stored configuration files between computers.

---

## OTHER PROGRAM FILES

Also within the Documents\Smaart LE directory are two more folders: *Skins* and *TargetCurves*.

The *Skins* folder contains any custom skins you make for Smaart in the *Skins* tab of the *Preferences* dialog (found in the *Options* menu). You can share a Smaart skin with a friend or to another machine by copying the custom skin’s .xml file from this directory and pasting it into the same directory on another computer.

The *TargetCurves* folder houses Target Curves available for display on Smaart’s *RTA* plots (see Target Curves on page 29 for more information). Target curves can be imported into Smaart via the *File > Import > Target Curve* function or via the *Options > Target Curves* dialog.

## 3 – CONTROLLING SMAART AND VIEWING DATA

Successful measurement sessions hinge upon the ability to control the program and display acquired data in a way that is useful to answer the questions at hand. This chapter is a look at all the interface elements and controls in Smaart.

### FUNDAMENTAL CONCEPTS

#### WAYS TO CONTROL SMAART

To allow for a wide variety of approaches, workflows and applications, there are multiple ways to control Smaart. The first is the mouse cursor, by interacting directly with onscreen data and controls, plus the menus and options dialogs that can be accessed via the program’s Menu bar at the top of the main program window on Windows computers, or at the top of the computer screen on macOS computers.

Second, Smaart offers a wide variety of hotkeys for various functions. A full list of hotkeys is available in the program’s help files, and any menu functions having hotkeys will list the key combination directly alongside the menu entry itself.

Alternatively, Smaart’s Command bar, across the bottom of the screen, offers Command Buttons that can be freely assigned to your favorite commonly used functions – simply click a Command button to execute the assigned function. You may wish to begin with the default assignments and gradually assign them to your preferred functions as you become more familiar with the program and establish a workflow.

#### CAPTURE VS DISPLAY

When working with Smaart, it is critical to distinguish between the measurement data itself, and how it is displayed. For example, when capturing a spectrum measurement, Smaart always stores the raw full resolution data, independent of what banding setting was in use at the time the data was captured. Since the raw, full resolution data has been retained, the data can later be displayed with any desired banding setting.

Conversely, when a measurement is captured, the measurement data is the result of whatever averaging setting the measurement engine was using at the time the data was produced and captured. Since the stored measurement was produced from the output of the average, the amount of averaging used cannot be changed once the data has been captured. In Smaart v9, care has been taken to locate the “view” settings in the plot itself, where the data is viewed, and locate the measurement settings – which affect how the measurement engines produce the data – within the measurement configuration dialogs. Thus, the interface and control paradigm are helpfully laid out in a way that helps to draw the distinction between data generation and data viewing.

#### LINEAR VS LOGARITHMIC PLOT SCALING

One thing we must be mindful of when measuring acoustic information and plotting it on graphs is that human perception of sound is logarithmic and covers a relatively large range of values. For example, the entire range of sound levels that humans can hear, between the threshold of audibility and the threshold of pain, is approximately 120 decibels, which in linear terms is a ratio of a million to one.

Likewise, the frequency range of human hearing is typically defined as 20 Hz to 20 kHz, a range of three “decades” or logarithmic orders of magnitude. Since we hear more or less logarithmically, our ears perceive the *percent difference* between two frequencies as a constant. In other words, we would perceive the jump from 500 Hz to 1 kHz as the same jump in frequency as 1 kHz to 2 kHz. In both cases, it’s a doubling of frequency (an “octave”). We usually plot our frequency-domain data on a logarithmic scale such that those two intervals occupy the same span on the graph.

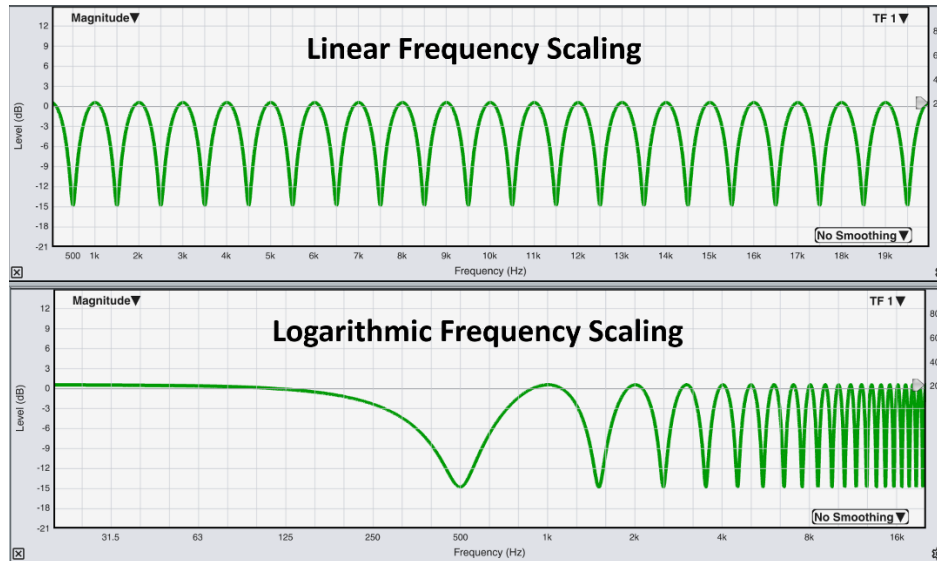

Figure 7 - Linear vs Logarithmic frequency scaling. Two views of the same comb filter.

This is what we mean when we refer to Linear or Logarithmic frequency scales – how frequencies are plotted on charts and graphs. On a linear frequency scale, every interval on the scale spans the same number of Hertz. (For example, a graph labeled in 100 Hz intervals). On a logarithmic scale, each span on the scale describes the same *percent change*. A common example is a chart with an octave scale, on which each octave is assigned the same span.

We usually view frequency domain data on logarithmic scales (most often labeled in Third-Octave, Octave, or Decade increments) since they correlate better with our perceptions of frequency. However, linear scales are very useful for some things as well, such as examining occurrences that are linear in nature like comb filtering and distortion harmonics, both of which typically occur every so many Hz.

When viewing raw FFT data on a logarithmic frequency scale, the trace tends to look fuzzier or busier at higher frequencies. This is a natural consequence of plotting data with linearly spaced data points on a logarithmic scale: the log scale packs more and more frequencies closer together as frequency increases. This is one of the reasons it is common to apply fractional octave banding to spectrum measurement data, and smoothing to transfer function data.

## DECIBELS

The decibel (dB) is a logarithmic unit that is used to express the ratio between two values (or a value and a reference value). Decibels are commonly used to express amplitudes, voltages, sound pressure, gain and

attenuation. Historically speaking, the decibel traces its roots to the Bel, a unit used to express logarithmic power ratios in the era of telephone technology (the unit's namesake is Alexander Graham Bell, commonly credited with the invention of the telephone). The knowledge that the decibel is a tenth of a Bel may demystify the formulas to some extent, since a Bel represents a power ratio of 10:1, and a decibel is a tenth of that.

Therefore we can express the ratio between two power levels, in dB, by:

$$dB = 10 \cdot \log_{10}(Power)$$

However, we often wish to express quantities other than power, most often voltage, amplitude, gain, or sound pressure. In those cases, since power is related to the square of amplitude:

$$Power = 10^{(dB/10)} = Amplitude^2$$

We can restate the decibel formula in terms of amplitude. The mathematical properties of exponents and logarithms tell us that we can move the “squared” term to the front of the equation and treat it as a coefficient instead, so the 10 becomes a 20:

$$dB = 10 \cdot \log_{10}(Power) = 20 \cdot \log_{10}(Amplitude)$$

Since decibels always express a ratio, they must be referenced to *something*. If no reference is explicitly given, the reference is assumed to be one. However, we can express the ratio between two values simply by dividing them before taking the log:

$$dB = 20 \cdot \log_{10}(v/v_0)$$

where  $v$  is some linear value that you want to convert to decibels and  $v_0$  is a reference value.

For example, the output of an amplifier is at 20 V while its input is at 0.5 V. We can find the voltage gain of the amplifier by:

$$dB = 20 \cdot \log_{10}(20/0.5)$$

or 32 dB.

Another common example of this in audio applications is dBu, which references 0 dB to 0.775 Volts rms. In this case you can convert an rms voltage  $v$  into dBu by:

$$dB = 20 \cdot \log_{10}(v/0.775)$$

---

### LINEAR VS LOGARITHMIC AMPLITUDE (TIME DOMAIN PLOTS)

Linear amplitude, as the name might imply, is amplitude displayed on a linear scale. In Smaart, the only place you will see this is on a linear time domain chart, where amplitude is displayed as a percentage of full scale. In other words, the largest possible (positive and negative) values are scaled to a range of 1 and -1.

Viewing Impulse Response data on a linear amplitude scale allows us to see relative polarity, and some people prefer the linear amplitude scale for identifying discrete reflections in an impulse response. A linear amplitude

scale is not as useful for looking at reverberant decay or for identifying peak structures in the low frequency range of an impulse response, where the waveform's period is spread over so much time that a clear impulse is not easily discernable.

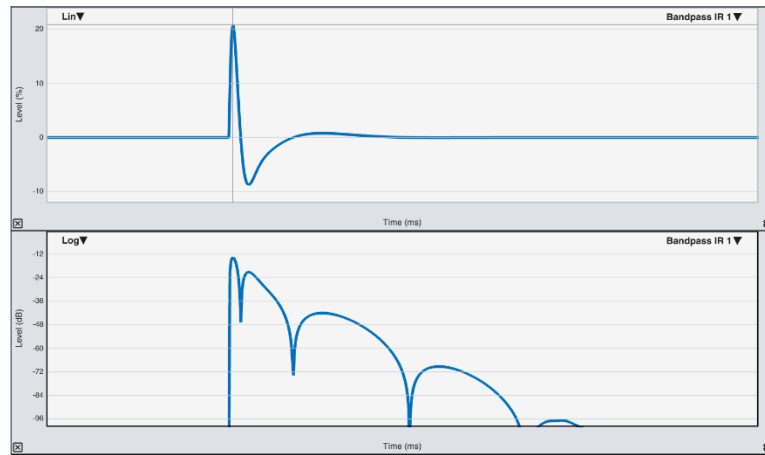

Figure 8 - Linear vs Logarithmic amplitude scaling. The impulse response of a filter is shown on a linear (percentage of full scale) vs logarithmic (decibel) amplitude scale.

## FOCUS

The concept of focus is a key element in working effectively within Smaart. Since Smaart can display multiple graphs at once, and each graph can contain multiple measurements at once, it is important to understand which plot or measurement your controls and command will affect.

## Z-ORDER

When one or more live measurements and/or stored data traces are present on a graph, they can be visualized as being stacked on top of each other, not unlike old overhead projector transparencies. Since the x axis is the plot's horizontal axis and the y axis is the vertical axis, the traces stack in the z axis, which you can visualize as stacking them on the axis that runs into the display, towards and away from the viewer.

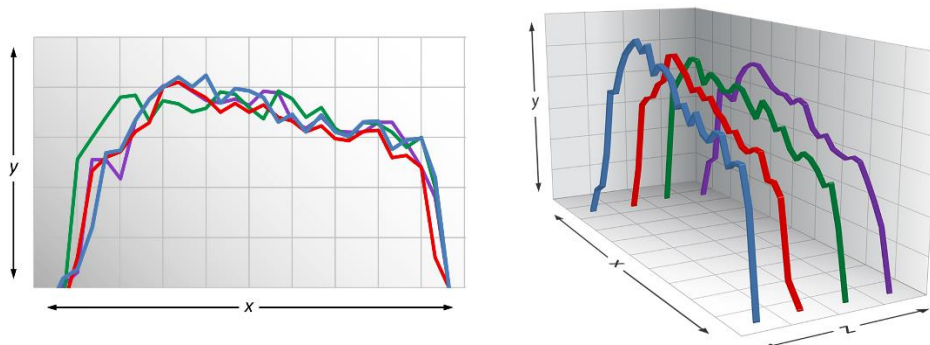

Figure 9 - a visualization of z-order in Smaart, showing how traces are stacked on the graph

The name of the frontmost trace in the z-axis stacking order (we also call this the top trace) always appears in the upper right corner of the graph pane. Clicking in the trace name, or the arrow next to it, will open the Plot

Legend which shows all live and stored measurement data displayed in the plot. Click on the name of any measurement in the Plot Legend list to bring it to the top of the stack.

You can also cycle the z order of a graph forward or backward by pressing the [Z] key or [Shift] + [Z] or by using the Cycle Z Order Forward and Cycle Z Order Reverse commands in the Command menu.

## PLOT FOCUS

When multiple plots are present, one of them is always considered the active or *focused* plot. Clicking anywhere within a plot selects it as active, and you can tell which plot is has focus by the thicker plot border highlight. When using Smart's default light skin, the focused plot will have a thicker black border around it, and when using the default dark skin, the focused plot will have a thicker white border around it. You can change the color of the plot focus indicator by navigating to the *Skins* tab of the *Options>Preferences* dialog and choosing a new color for the *Plot Area grid border (focused)* item.

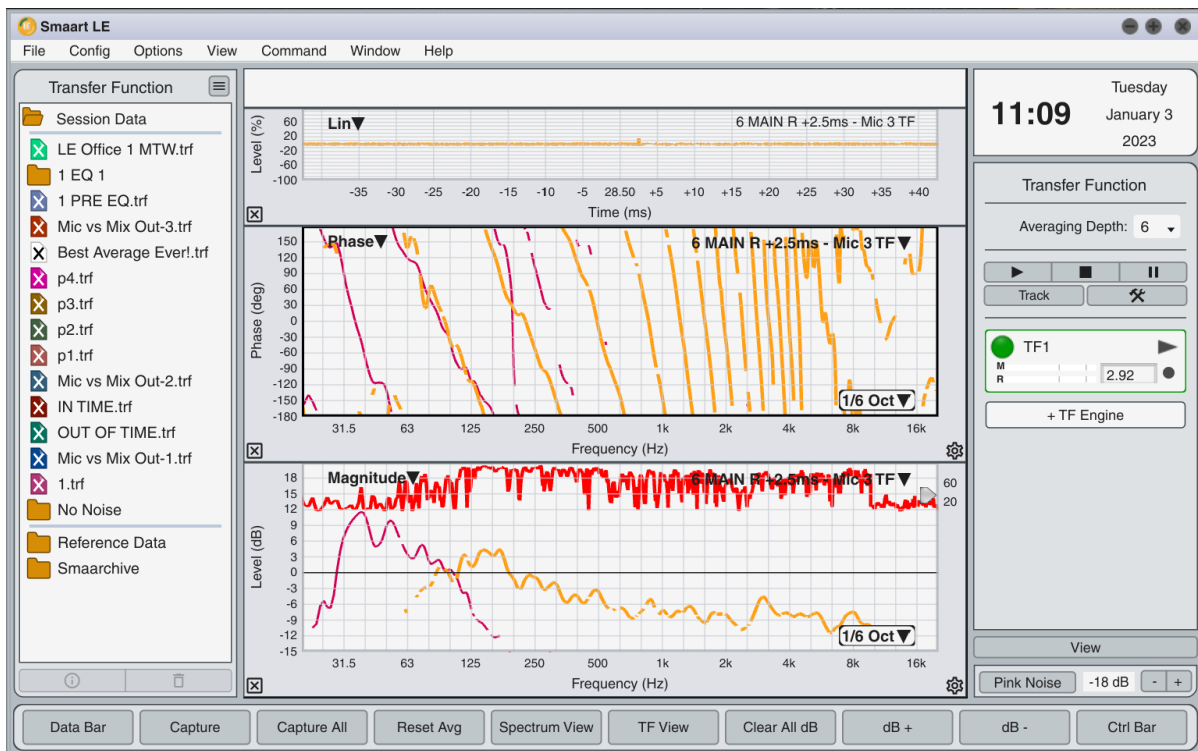

Figure 10 - an example of Plot Focus in Smart. Notice how the Phase graph has a thick, dark inner border, indicating focus.

The focused plot will determine which controls you see in the Control Bar and which set of captured data you see in the Data Library (Spectrum or Transfer Function).

The focused plot is the source for data capture operations – in other words, when you execute the Capture command [Spacebar], the live measurement data on the top of the z order in the focused plot is what will be captured. The focused plot is also the target for most menu and keyboard commands that affect what you see on a graph, such as zoom commands, or cycle z-order commands.



## ENGINE FOCUS

Like Plot Focus, you can click on a measurement engine in the Control Bar to give it focus, which is indicated by a thicker colored border around the engine and a different shading color on the engine. When a Transfer Function engine has focus, it is enlarged to make room for the additional delay controls (Find, Track, and Increment/Decrement delay). If a measurement engine's data is currently shown in a plot, clicking the engine to give it focus also brings its data to the top of the z order.

## VIEW, DATA, AND PLOT CONTROLS

### PLOT VIEW CONTROLS

#### PLOT TYPE CONTROL

All plots in Smaart follow the same convention for identification and navigation: the upper left corner of each plot shows the type of graph (*RTA*, *Spectrogram*, *Magnitude*, *Phase*, etc). Click the plot label text or the arrow next to it to open the droplist and change the plot to a different type.

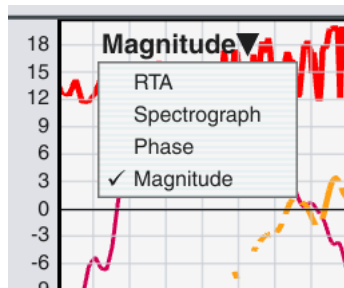

Figure 11 - Plot Type control droplist

#### ADDING / REMOVING PLOTS

Each plot in Smaart LE has a small [x] icon at the lower left corner of the plot border area. Click this [x] to remove the plot from the graphing area. When the graph area is occupied by a single plot, the [x] icon will change to a plus [+] icon. Clicking the plus [+] icon will add a second plot to the graph area. Thus, you are able to switch between one plot and two plots directly from the graphing area.

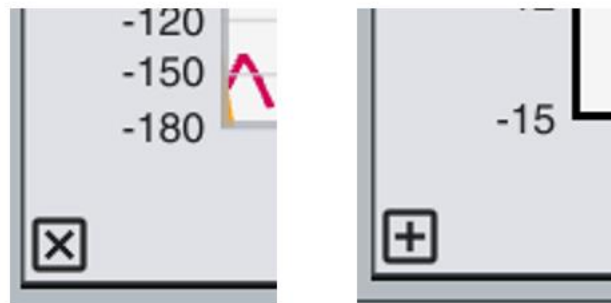

Figure 12 - the X icon (left) will remove a plot, and the plus icon (right) will add another

## VIEW FLYOUT AND VIEW PRESETS

At the bottom of the Control Bar, just above the Signal Generator, is the View button, which opens the View flyout. At the top of the View Flyout are six buttons that control various View settings.

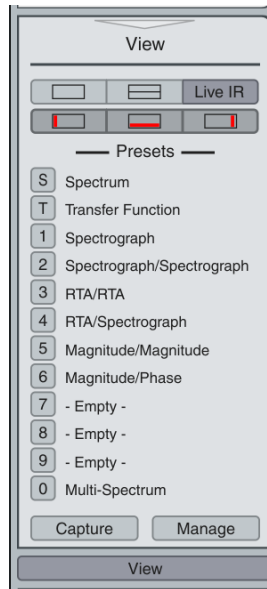

Figure 13 - Control Bar View flyout

The first two are the “one plot / two plot” buttons used to divide the main plot area into either one or two plots. The button labeled with a single rectangle sets the graph area to a single plot, and the button labeled with two rectangles splits the graph area into two plots. The rightmost button in the top row toggles the *Live IR* pane when a Transfer Function-type plot (either *Magnitude* or *Phase*) is visible.

The second row of controls will show and hide various sections of the interface: from left to right, the Data Bar, the Command Bar, and the Control Bar. (Remember that these elements can also be shown and hidden via the *View* menu at the top of the screen, or via hotkeys.)

Below the six view buttons is the Presets area, where you can recall the *Spectrum* and *Transfer Function* preset views as well as ten user-definable view presets by clicking the associated button. The same presets can be recalled without opening the flyout by pressing the associated hotkey ([S], [T], or a number from 0 to 9).

Click the *Capture* button at the bottom of the flyout to capture the current view configuration, give it a name and choose a slot to store it in. The *Manage* button opens the *User Views* dialog, where you can capture, recall, delete or rename view presets, and reorder the list with the up and down arrow buttons.

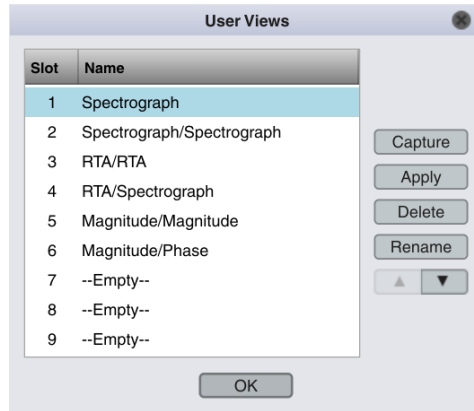

Figure 14 - User Views dialog

You can also recall View Presets and access the *User Views* dialog from the *View > View Presets* menu.

---

## PLOT CONTROLS

### PLOT SCALE

Smart LE offers four scaling options for frequency-domain plots (*RTA*, *Spectrograph*, *Magnitude* and *Phase*): three logarithmic options (*Decade*, *Octave* and *1/3 Octave*, which is the default), and a *Linear* option as well. All three logarithmic options plot the data on a logarithmic frequency scale and simply change the grid ruling.

The plot scale setting is located in the *Graph Settings* dialog, which can be accessed by clicking the Gear icon in the bottom right corner of the plot border area, or via the *Options > Graph Settings* menu, or the associated hotkeys, [alt] + [S] for Spectrum graph settings and [alt] + [T] for Transfer Function graph settings. See Graph Settings for more information on the graph settings dialog.

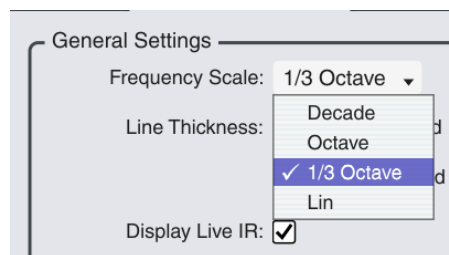

Figure 15 - Plot Frequency Scale settings, in Graph Options

---

## ZOOMING

You can zoom in and out of any graph in Smart by use of the mouse, hotkeys, or user-definable zoom range presets.

- Press the plus and minus keys ([+] and [-]) on your keyboard to zoom in and out on the y (vertical) axis of the active graph.
- Hold down [Ctrl/Cmd] + [Alt/Option] while pressing plus or minus to zoom in/out on the x (horizontal) axis of the active graph.
- Hold down [Ctrl/Cmd] while pressing plus or minus to zoom both the x and y axis.

You can also right-click (or [Ctrl] + click on macOS) and drag with your mouse to draw a “rubber band box” around the area you want to zoom in. When you release the mouse button, the selected area will fill the entire graph.

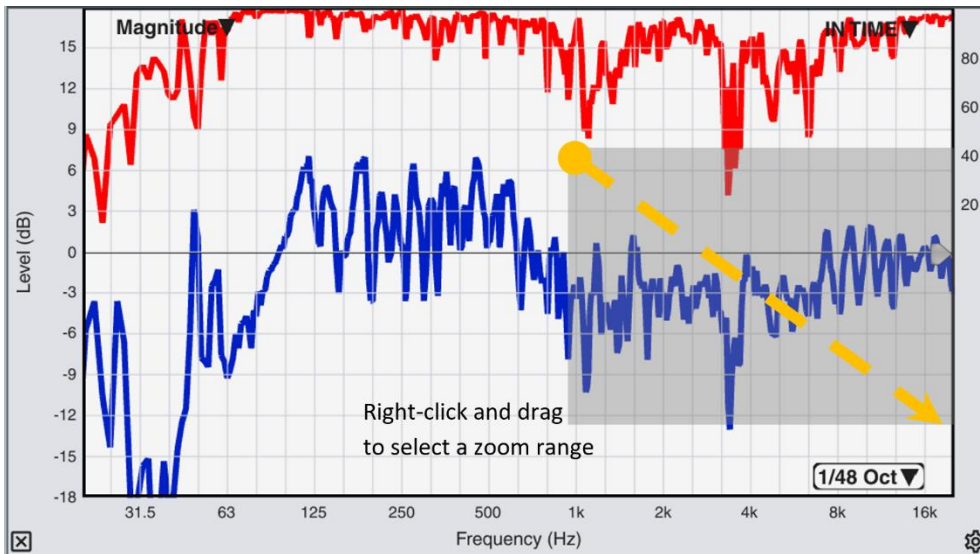

Figure 16 - Rubber Band (right-click) zooming

Remember that you can always click in the border of any plot to restore it to default zoom range.

### Zoom Presets

Zoom presets enable you to set the x-axis range of a graph (the time or frequency axis) to a predefined range. Zoom presets are activated by selecting *Zoom > Zoom 1-4* from the *Command* menu or by pressing [Alt/Option] + [1-4] on your keyboard. Selecting *Default* from the *Zoom* menu, pressing [Alt/Option] + [5], or simply clicking anywhere in the border of a plot will restore it to its default x and y ranges.

You can customize the zoom presets via the *Zoom* tab of the *Preferences* dialog opened via *Options > Preferences*. There are separate settings for Frequency and Time domain plots. Settings in the *Frequency* section define preset zoom ranges for frequency domain plots (*RTA*, *Spectrograph*, *Magnitude* and *Phase*). Settings in the *Relative Time* section define time ranges for the Transfer Function *Live IR* display.

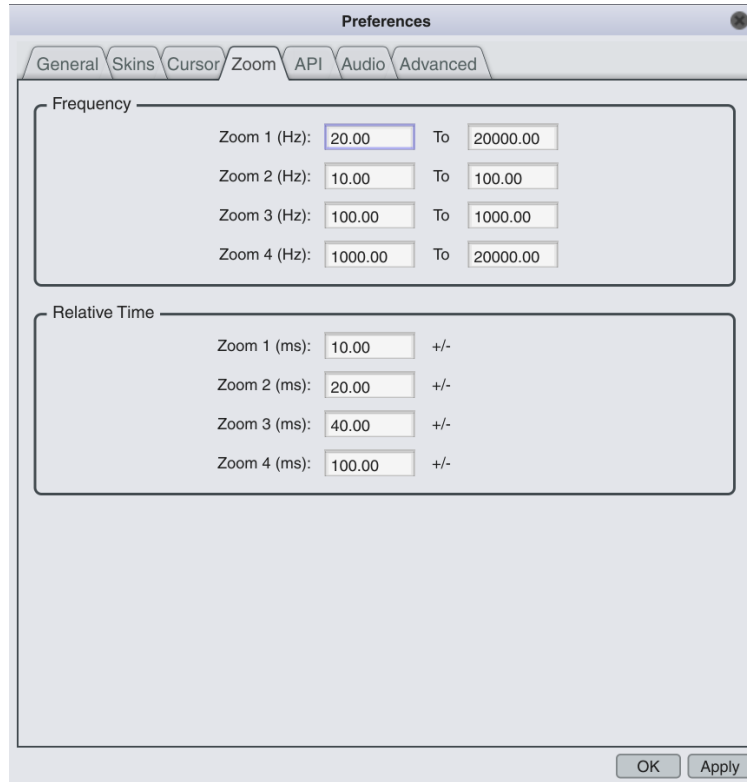

Figure 17 - Zoom Preferences

## TARGET CURVES

A target curve in Smart is simply a line with a specified spectral shape that is drawn on banded *RTA* displays (only) at a specified level. The purpose of a target curve is simply to be visible on the screen as a reference, for example when measuring background noise or when attempting to achieve a certain signal spectrum in the case of a music mix, speech privacy system, or a cinema sound system's *X* curve.

Target curves cannot be moved up or down the plot in the way that measurement data can. They move up or down automatically to accommodate changes in banding resolution, but otherwise their position is fixed. They do not appear in the plot legend, and the cursor readout ignores them. Also, target curves are not displayed on un-banded spectrum displays, or on transfer function plots. If you need a target curve in a *Magnitude* plot, you can create one by setting an equalizer or processor to the desired response, then simply measuring the processor's response and saving it as measurement data.

To view and manage available target curves, select *Options > Target Curves* or use the hotkey [Alt/Option] + X to open the *Target Curves* dialog. For each available curve, you can set the display status, line color and thickness. You can also *Import* new target curves or *Delete* existing ones from this window.

Once you have selected target curves for use, open the *View* menu and select *Show Target Curves*, or press [X] on your keyboard to display the target curves. Note that target curves display at a specific SPL so you may need to scroll the *RTA* plot to see them.

## GRAPH SETTINGS

Smaart LE offers a host of options to control and customize graphing. Graph settings in Smaart are accessible via the *Options > Graph Settings* menu and broken into separate tabs for *Spectrum* and *Transfer Function* graphs. You can also access *Graph Settings* directly by clicking the Gear icon in the lower right corner of the plot border on *RTA*, *Spectrograph*, *Magnitude* or *Phase* plots.

Alternatively, open *Spectrum Graph Settings* by using the hotkey [Alt/Option] + [S], or *Transfer Function Graph Settings* by using the hotkey [Alt/Option] + [T].

## SPECTRUM GRAPH SETTINGS

The *Spectrum Graph Settings* dialog is divided into three sections – *General Settings*, *RTA Display Settings*, and *Spectrograph Settings*. At the bottom of the dialog is a button to quickly jump to the *Spectrum Measurement Settings* dialog.

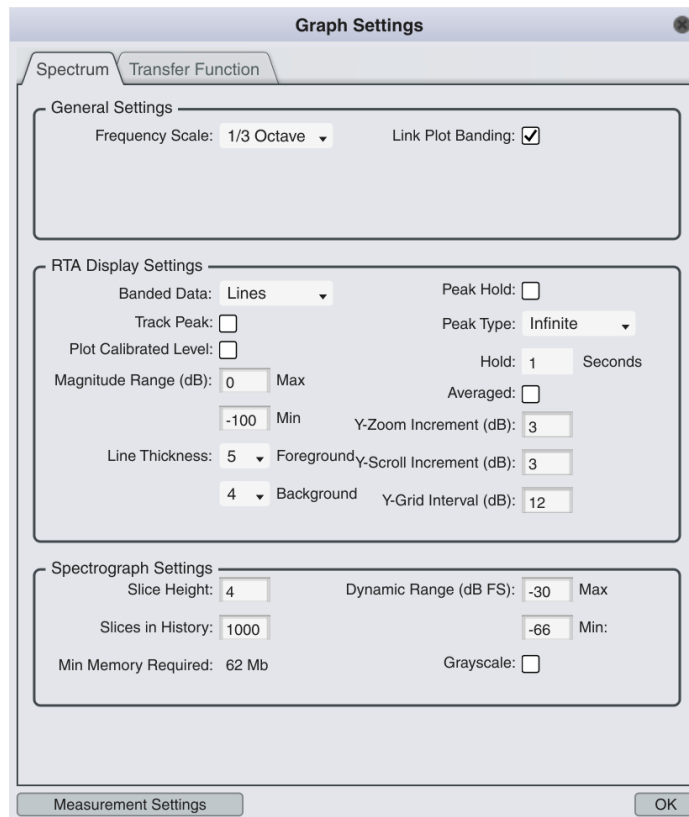

Figure 18 - Spectrum Graph Settings

### General Settings

*Frequency Scale* controls the x (frequency) axis scaling for *RTA* and *Spectrograph* plots. Smaart LE offers four scaling options: three logarithmic options (*Decade*, *Octave* and *1/3 Octave*, which is the default), and a *Linear* option as well. All three logarithmic options plot the data on a logarithmic frequency scale and simply change the grid ruling. As explained in *Linear vs Logarithmic Plot Scaling*, frequency response data is normally displayed on a logarithmic frequency axis, however you may wish to view it on a linear axis in certain contexts.

*Link Plot Banding*, which is enabled by default, keeps the in-plot *Banding* setting linked for all Spectrum-type plots (RTA and Spectrograph). Disabling this setting will allow you to set banding independently for each RTA and Spectrograph plot using the in-plot control in the lower right of each plot.

### RTA Display Settings

*Banded Data* selects whether you want Smaart to display RTA data as a bar chart with fractional octave banding, a line graph, or *Both*. Selecting *Both* will plot a combination of fractional octave data in bar chart form with the raw, un-banded FFT data overlaid as a line graph. Un-banded FFT data is always plotted as a line graph (i.e. when the in-plot banding control is set to *None*).

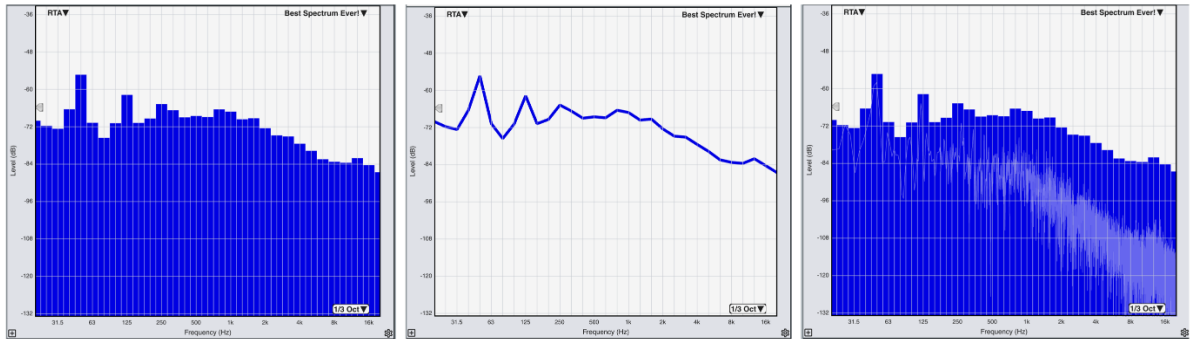

Figure 19 - RTA Display Settings (Bars, Lines, or Both)

*Peak Hold* – RTA data is typically averaged over some period, which helps stabilize the data to make it more readable and give an idea of trends over time. Selecting *Peak Hold* will also display a record of the highest level reached by the peaks in the signal at each frequency, or in each band. Peak Hold data is plotted as a second line on line graphs, or as a series of flattened bar segments on bar charts. You can also toggle the *Peak Hold* setting via *View > Toggle Peak Hold* or by pressing the [P] key on your keyboard. When you capture a spectrum measurement, both the normal RTA trace and the peak hold data are stored in the captured measurement. This means that you can view Peak Hold data in the future even if the setting was not enabled at the time of the capture.

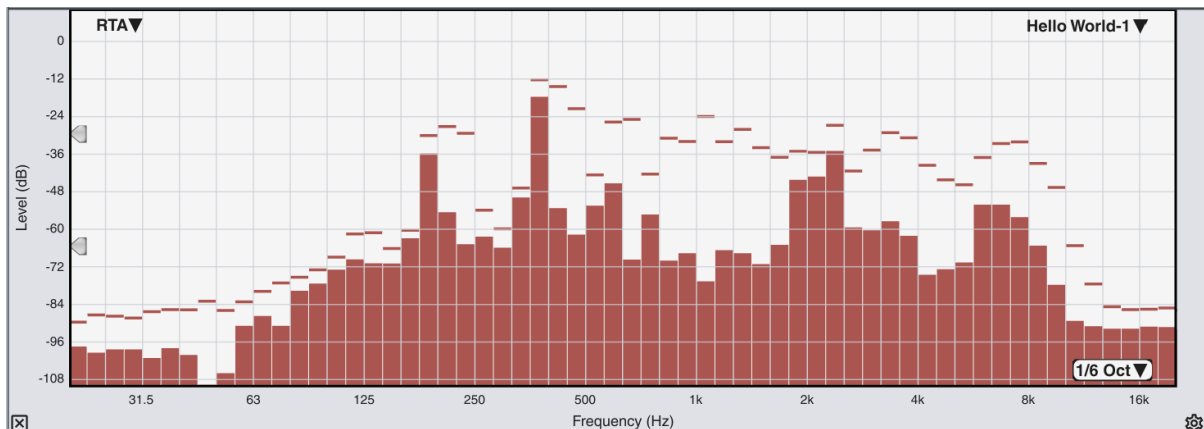

Figure 20 - RTA with Peak Hold enabled

*Track Peak* will enable a second “crosshair” cursor that tracks the magnitude and frequency of the data point with the highest amplitude value in the in the top-most trace on the RTA plot. When your mouse cursor is

located in that plot, the cursor readout area will display the magnitude and frequency of the tracked peak as well in addition to the usual cursor readout information.

*Peak Type* selects the peak hold time. The choices are *Infinite* or *Timed*. *Infinite* peak hold preserves the highest peak level recorded for reach frequency until it is either replaced by a higher reading, or you flush the averaging buffer ([V] key). *Timed* peak hold allows the peak trace to decay after some number of seconds, as specified in the *Hold* field.

*Averaged* – By default, the peak hold function looks for the highest peaks in each incoming FFT, before the data goes into the average for the normal RTA display, meaning that you may never see an averaged RTA trace approach the peak levels. If you want to see the highest levels reached by the averaged signal instead, click the *Averaged* check box.

*Plot Calibrated Level* applies the input's calibration offset (if present) to *RTA* plots and sets the default *RTA* display range from 20 dB to 120 dB. Inputs with a calibration offset present are plotted on the *RTA* graph in dB SPL (positive values). This means that, when this option is selected, plotting a combination of spectrum measurements from calibrated and non-calibrated inputs will result in traces being graphed in both the positive and negative regions of the vertical scale at once. When this option is not selected, Smaart ignores any calibration offsets and plots all spectrum measurements in dBFS (negative values).

*Magnitude Range (dB)* sets the default decibel range for the *y* (vertical) axis of *RTA* plots. Note that since these controls set the *default* range, it will not have any effect on the plot as currently displayed. Click anywhere in the plot border to reset to the (new) default view range.

*Y-Zoom Increment (dB)* sets the increment that will be used to zoom the vertical scale of *RTA* plots when the [+] and [-] keys are pressed.

*Y-Scroll Increment (dB)* sets the increment that will be used to scroll the vertical scale of *RTA* plots when the up and down arrow keys are pressed.

*Y-Grid Interval (dB)* sets the *y* axis grid ruling interval for *RTA* plots, in decibels.

*Line Thickness* adjusts the thickness, in pixels, of line traces displayed on *RTA* plots. Thickness for foreground (top of *z* order) and background traces can be adjusted independently.

### Spectrograph Settings

*Slice Height* sets the height, in pixels, of each row in the Spectrograph display. Changes will take effect immediately. Slice Height can also be adjusted using the [+] and [-] keys while any *Spectrograph* plot has focus.

*Slices in History* sets the maximum number of *RTA* rows kept in the spectrograph history (in other words, how far back you can scroll the plot and still see data). More rows require more memory, especially with large FFT sizes, as indicated by the *Max Memory Required* field.

*Dynamic Range (dB FS)* sets the upper and lower thresholds for the spectrograph display, in decibels. Data points whose magnitude values fall below the specified *Minimum* value are displayed in black, and levels that exceed the *Max* value are set to white. The dynamic range can also be controlled by the two arrowhead-shaped widgets that appear along the left edge of the *Spectrograph* and *RTA* plots, see Spectrograph on page 64.



*Grayscale* changes the spectrograph to use shades of gray, rather than colors.

---

## TRANSFER FUNCTION GRAPH SETTINGS

The *Transfer Function Graph Settings* dialog is divided into three sections – *General Settings*, *Magnitude*, and *Coherence*. At the bottom of the dialog is a button to quickly jump to the *Transfer Function Measurement Settings* dialog.

### General Settings

---

*Frequency Scale* controls the x (frequency) axis scaling for *Magnitude* and *Phase* plots. Smaart LE offers four scaling options: three logarithmic options (*Decade*, *Octave* and *1/3 Octave*, which is the default), and a *Linear* option as well. All three logarithmic options plot the data on a logarithmic frequency scale and simply change the grid ruling. As explained in *Linear vs Logarithmic Plot Scaling* on page 20, frequency response data is normally displayed on a logarithmic frequency axis, however you may wish to view it on a linear axis in certain contexts.

*Link Phase & Mag. Smoothing*, which is enabled by default, keeps the in-plot *Smoothing* setting linked for all Transfer Function-type plots (*Magnitude* and *Phase*). Disabling this setting will allow you to set smoothing independently for *Magnitude* and *Phase* plots using the in-plot control in the lower right of each plot.

*Line Thickness* adjusts the thickness, in pixels, of line traces displayed on *Magnitude* and *Phase* plots. Thickness for foreground (top of z order) and background traces can be adjusted independently.

*Plot Proportional Graphs* expands the *Live IR* pane to occupy an equal portion of the graph area as the other plots, rather than a smaller, fixed-height pane.

*Display Live IR* sets whether the *Live IR* pane is shown whenever a Transfer Function plot type (*Magnitude* or *Phase*) is displayed. This setting can also be toggled using the *Live IR* button at the top of the View flyout, or via the key command [Ctrl/Cmd] + [I].

### Magnitude

---

*Mag Range (dB)* sets the default vertical zoom range for *Magnitude* plots. Note that since these controls set the *default* range, it will not have any effect on the plot as currently displayed. Click anywhere in the plot border to reset to the (new) default view range.

*Y-Grid Interval (dB)* sets the y axis grid ruling interval for *Magnitude* plots, in decibels.

*Y-Scroll Increment (dB)* sets the increment that will be used to scroll the vertical scale of *Magnitude* plots when the up and down arrow keys are pressed.

*Y-Zoom Increment (dB)* sets the increment that will be used to zoom the vertical scale of *Magnitude* plots when the [+] and [-] keys are pressed.

### Coherence

---

*Show Coherence* sets whether Coherence data is displayed for the trace at the top of the z order in *Magnitude* plots. You can also *Toggle Coherence* via the View menu, or by pressing [C] on your keyboard.

*1/4 Height* vertically compresses the coherence display into the top quarter of the *Magnitude* plot rather than the top half. Selection this option if you want more unobstructed plot space for magnitude traces.

*Coh Blanking Threshold* sets the coherence threshold below which magnitude and phase data will not be plotted. Frequency data points having coherence values lower than the threshold will not be displayed in the plot, however the data is still calculated and captured. In other words, the coherence blanking threshold setting has no effect on the underlying measurement data, only whether it is displayed. See Coherence on page 68.

---

## DATA CONTROLS

---

### SHOWING AND HIDING DATA

The data shown in Smaart LE's graphs comes from two places: either Live measurement data that is produced by a measurement engine in the Control Bar, or Stored data that was previously captured from a measurement engine and is stored in the data library. In the case of Live measurement data, the colored circle on the measurement engine controls whether that engine's data trace is shown or hidden.

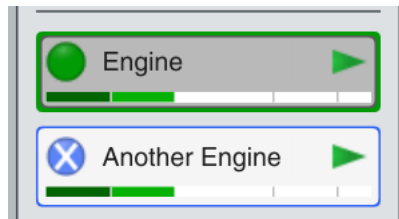

Figure 21 - Two Spectrum engines in the Data bar. The Green engine is currently shown, and the Blue engine is hidden, as indicated by the X across the colored circle icon

Clicking the colored circle will hide the engine's data, which is indicated by the X that appears over the colored circle. Clicking again will remove the X and display that engine's data in the plot, provided of course that the engine has data in its buffer to display. Each Live measurement trace displayed in a plot will be the same color as the measurement engine that is producing it and will be identified in the Plot Legend by a colored circle that matches the colored circle in the measurement engine.

In the case of stored measurement data, files that are not currently displayed have an X displayed on their file icons in the Data Bar. Clicking the colored file icon will display that data in the plot and remove the X to indicate that it is shown. Clicking the file icon again will restore the white X and hide the data from the plot. You can also use the hotkey [H] to hide the focused trace, or [Ctrl/Command] + [Shift] + [H] to hide all stored traces displayed in all plots. You can also find these commands in the *Command > Stored Data Traces* menu.

You can also hide traces directly from the Plot Legend, by clicking the *Hide* button to hide the focused trace, or by clicking the colored icon (circles for live data and pages for stored data) to hide any trace.

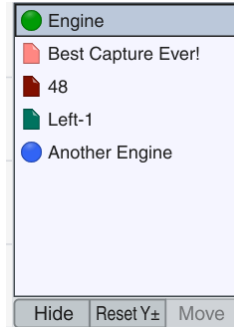

Figure 22 - Plot Legend showing a mixture of live data (circle icons) and stored data (page icons)

You can also quickly show multiple stored traces by holding the [Ctrl/Cmd] key and clicking to select multiple traces, or a range of traces by clicking to select the first trace you wish to display, then holding the [Shift] key and clicking the last, and then dragging the selected traces into the graphing area. You can also display an entire folder of stored data by dragging the folder into the graphing area.

### MOVING TRACES

When two plots of the type are displayed (for example, two *RTA* plots), you can move displayed data between plots by clicking it in the Plot Legend to give it focus and move it to the top of the z order and then clicking the *Move* button. You can also move the focused trace to the other plot by pressing [M] on your keyboard, or via the *Command* menu > *Cycle Preferred Plot*.

In addition, you can double click a measurement engine in the Control Bar to open its settings and then adjust the *Plot* setting between 1 and 2 to choose which plot it displays in by default. Similar, you can access a stored trace's *Trace Info* dialog, either by right-clicking it in the Data Bar and choosing *Info* or by using the Info icon at the bottom of the Data bar, and setting the *Plot* setting to either 1 or 2.

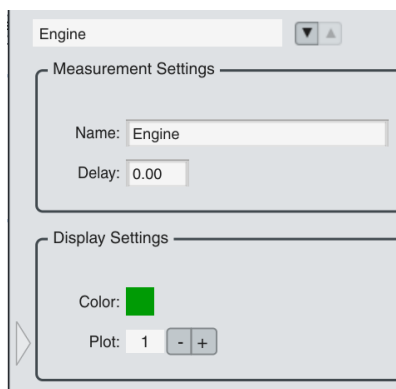

Figure 23 - Plot Preference control in the measurement engine config flyout

### TRACE OFFSET

Smart allows you to move traces up or down on a graph by applying a trace offset (also referred to as “y-offset”, “vertical offset” or “dB offset”). You can apply an offset to the focused trace by using the *dB +* and *dB -* buttons on the command bar, or by the [Ctrl/Cmd] + Up/Down arrow hotkeys. These commands nudge the focused trace up or down by the increment specified in the *Trace Movement* setting of the *Options* >

*Preference* dialog. The default setting is 1 dB. Another way to move a trace up or down on the graph is to click and drag it with your mouse.

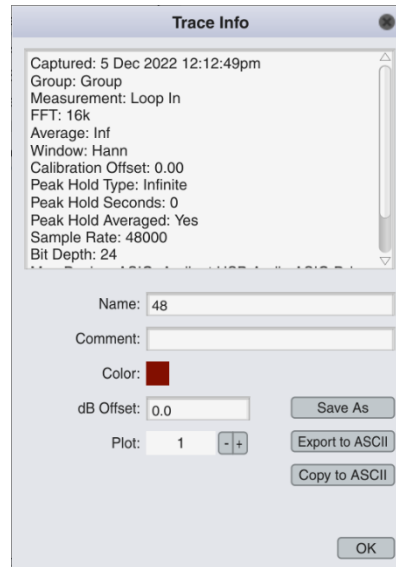

Figure 24 - Trace Info dialog showing fields for Plot Preference and dB Offset

When a trace has an offset applied, the offset amount is displayed in the upper right corner of the plot, below the trace name, when the trace has focus. The offset for every trace on a plot is also displayed in the plot legend. You can also view and adjust the offset for stored traces using the *dB Offset* setting in the *Trace Info* dialog.

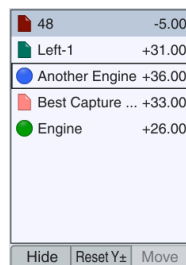

Figure 25 - Plot Legend showing dB Offset for each trace.

You can clear the offset for the focused trace by using the [Y] hotkey or *Command > Clear dB Offset*. Clear all offsets for all traces displayed in a plot by clicking the *Reset Y±* button in the Plot Legend. Clicking the button a second time before closing the Plot Legend will restore the offsets.

Clear all trace offsets at once using *Command > Clear All dB Offsets* or the hotkey [Ctrl/Cmd] + [Y].

## TRACE COLOR AND THICKNESS

You can set the color for live data traces by right clicking the associated measurement engine in the Control Bar and choosing *Change Color*, or by double-clicking the engine to open its settings and clicking the *Color* swatch. You can change the color of stored data by right-clicking and choosing *Info*, or using the Info button at the bottom of the Data Bar, to open the *Trace Info* dialog, then clicking the *Color* swatch.

In the *Color Selection* dialog, you can use the color picker to drag the selectors to a new color, or select Red, Green and Blue hex values individually, or select a pre-selected color from the palate. Clicking any color in the pre-selected color palate will open a menu asking whether you want to use that swatch color as the trace color, or re-assign the swatch color to the color value currently indicated by the drag selector and the Red/Green/Blue sliders.

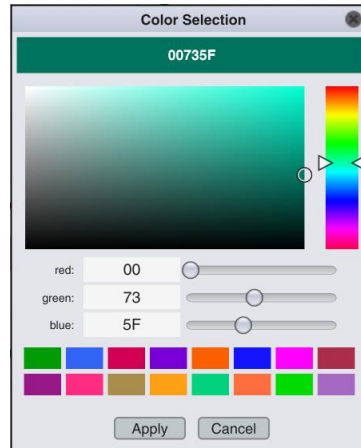

Figure 26 - Color Selection dialog

Alternatively, you can select one or multiple traces in the Data Bar, right click, and choose *Assign Random Color* to quickly re-color them all.

The thickness of traces displayed in graphs can be adjusted separately using the *Line Thickness* controls in the *Spectrum* and *Transfer Function* tabs of the *Graph Settings* dialog, which you can access by clicking the Gear icon in the bottom right corner of the plot border. You can set the thickness, in pixels, for the foreground (focused) and background traces independently.

## Z-ORDER

When one or more live measurements and/or stored data traces are present on a graph, they can be visualized as being stacked on top of each other, not unlike old overhead projector transparencies. Since the x axis is the plot's horizontal axis and the y axis is the vertical axis, the traces stack in the z axis, which you can visualize as stacking them on the axis that runs into the display, towards and away from the viewer.

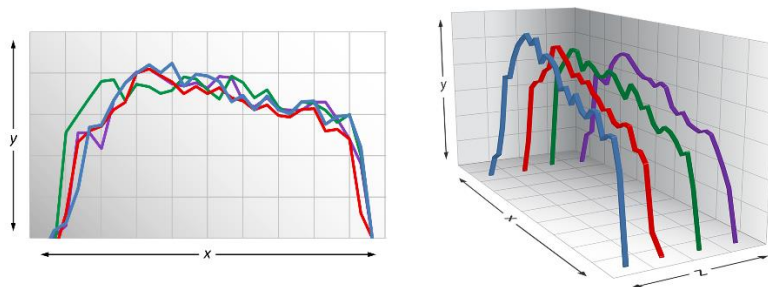

Figure 27 - a demonstration of z-order in Smart

The name of the frontmost trace in the z-axis stacking order (we also call this the top trace) always appears in the upper right corner of the graph pane. Clicking in the trace name, or the arrow next to it, will open the Plot

Legend which shows all live and stored measurement data displayed in the plot. Click on the name of any measurement in the Plot Legend list to bring it to the top of the stack.

You can also cycle the z order of a graph forward or backward by pressing the [Z] key or [Shift] + [Z] or by using the Cycle Z Order Forward and Cycle Z Order Reverse commands in the Command menu.

---

## PLOT LEGEND

The Plot Legend is accessed by clicking in the upper right corner of a plot, either on the name of the displayed trace, or the arrow next to it. The Plot Legend lists all traces currently displayed in the plot, both live measurements (indicated by a colored circle) and stored data (indicated by a page icon). Each icon is colored to match the display color of the corresponding trace in the plot. Clicking anywhere outside the Plot Legend will close it.



Figure 28 - Plot Legend showing a mixture of Live and Stored data

The currently focused trace – the one at the top of the z order – always appears at the top of the list, with a shaded highlight. Clicking any on any trace name in the Plot Legend moves it to the top of the list, and to the top of the z order in the plot. Clicking the colored icon next to the trace name – the circle for live data and the page icon for stored data – will hide that trace from the plot.

Below the legend are three buttons. The *Hide* button will hide the trace at the top of the z order. The *Reset Y±* button clears all dB offsets applied to all traces in the plot. While the legend remains open, you can click the button again to restore the offsets. When two plots of the same type are visible, the *Move* button will move the focused data to the other plot.

---

## TRACE INFO

You can access the *Trace Info* dialog for any stored measurement data by right-clicking the stored data in the data bar and choosing *Info*, or by selecting the stored data and then clicking the Info icon at the bottom of the data bar.

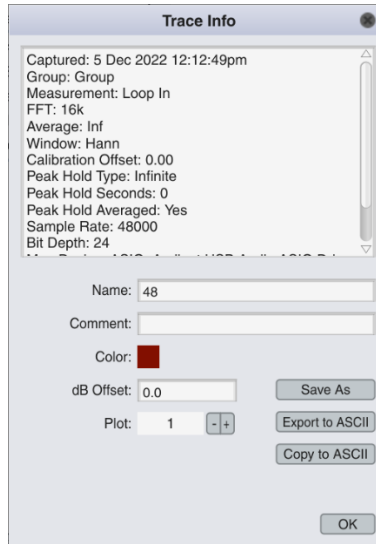

Figure 29 - The Trace Info dialog

The upper portion of the *Trace Info* dialog lists everything that Smart knows about the captured measurement data, including when it was captured, the name of the measurement engine that produced the data and details about the measurement engine's configuration. It also lists the IO device and input channel names used to acquire the measurement signals, and the version of Smart that captured the data.

The lower portion of the *Trace Info* dialog has an editable *Name* field (be sure to press [Enter] to set the change) plus a *Comment* field for storing any additional information you wish to make note of.

Clicking the *Color* swatch opens the *Color Picker* to allow you to change the display color of the trace.

The *dB Offset* field allows you to view and adjust the current y offset applied to the trace, if any.

*Plot* sets which plot the trace will appear on, in situations when more than one of the same plot type is available, for example, the *RTA/RTA* view for *Spectrum* data or the *Magnitude/Magnitude* view for *Transfer Function* data. When only a single plot of a given type is available, this setting is ignored. See *Moving Traces* on page 35.

*Invert Mag Display* appears as an additional option for *Transfer Function* traces. When enabled, it will display the trace's magnitude response upside down. This can be helpful when setting loudspeaker equalization, as it allows a cut to be displayed as a boost, making it easier to see whether the filter response is appropriately complementary to the loudspeaker response being equalized.

*Save As* will allow you to save a copy of the trace file to another destination on your computer.

*Copy to ASCII* copies the data from the selected stored data file to the operating system's clipboard in tab-delimited ASCII text format, suitable for pasting into a spreadsheet, text editor, or any other program that accepts ASCII text. ASCII exports of spectrum data consist of three columns: frequency, magnitude, peak magnitude (as dictated by the *Peak Hold* options in *Spectrum Graph Settings*) and column headers. ASCII exports of transfer function data include frequency, magnitude, phase and coherence plus column headers.

*Export to ASCII* exports the data from selected file(s) to tab-delimited ASCII text files. You will be prompted to choose or create a destination directory for the exported files.

## BANDING AND SMOOTHING

### BANDING

When spectrum data is displayed on a logarithmic scale, it is most often displayed using fractional octave banding, which aggregates the signal's energy into bands that are of constant log width (that is, each band is an octave wide, or a third of an octave wide, and so forth). This helps the displayed spectrum correlate well with human logarithmic pitch perception, and helps spectrum displays appear in a way that tends to visually resemble the tonality of the signal as we perceive it.

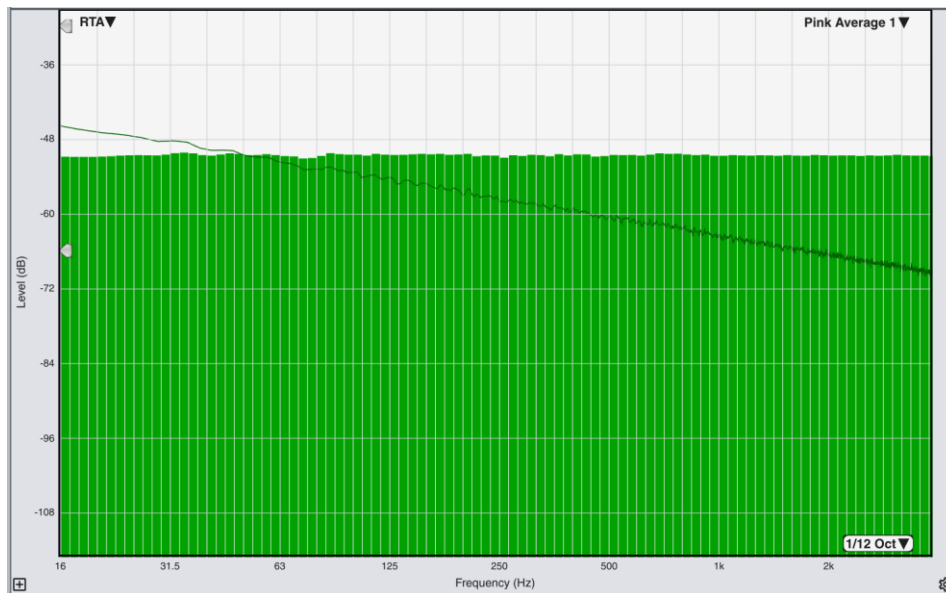

Figure 30 - Banded (bars) and unbanded (lines) RTA data displayed on the same plot. Note that the banding is what makes the pink noise signal appear "flat"

In Smaart LE, the banding setting is a *display* setting – that is, it doesn't affect the underlying measurement data, just how it is displayed. Spectrum data is always captured in full resolution and can then be displayed with any banding desired at any point in the future.

RTA plots can display banded data as a bar chart or a line graph. The *Spectrum* tab of the *Graph Settings* dialog, which is accessible by clicking the Gear icon in the bottom right of the plot border area, or via *Options > Graph Settings > Spectrum*, or via the hotkey [Alt/Option] + [S], has a *Banded Data* setting that will allow you to choose whether you wish to see Bars, Lines or both. Selecting *Both* will plot a combination of fractional octave data in bar chart form with the raw, un-banded FFT data overlaid as a line graph.



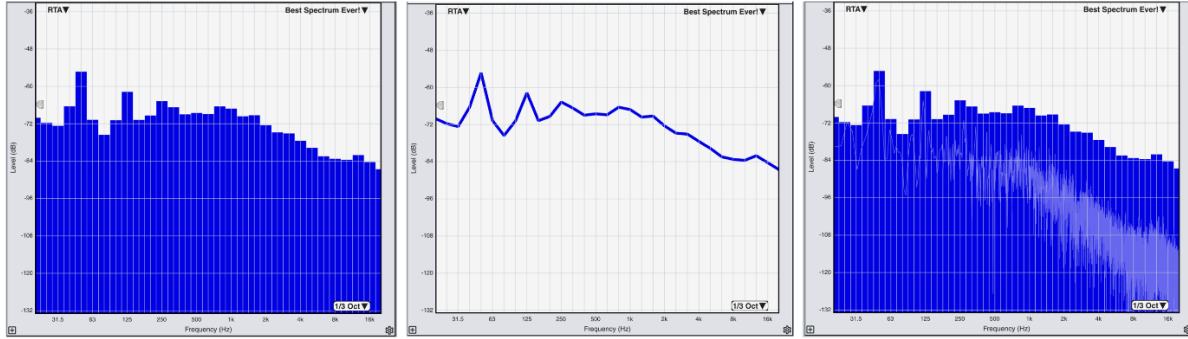

Figure 31 - RTA display options: Bars, Lines, or Both

The banding can be adjusted via the in-plot banding control in the lower right corner of spectrum-type plots (*RTA* and *Spectrograph*). When the banding control is set to *None*, the un-banded data is always displayed as a line graph.

By default, the banding settings for *RTA* and *Spectrograph* plots are linked, but you can un-link them in *Spectrum Graph Settings* by de-selecting the *Link Plot Banding* checkbox.

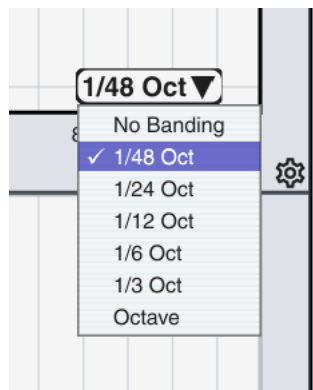

Figure 32 - In-plot Banding Control

## SMOOTHING

Transfer function data (*Magnitude* and *Phase*) is often displayed with some amount of fractional-octave smoothing applied, to help illustrate trends and make the data more readable by reducing visual “noise” in the measurement, especially when using large FFT sizes that create large numbers of data points.

In Smart LE, the smoothing setting is a *display* setting – that is, it doesn’t affect the underlying measurement data, just how it is displayed. Transfer function data is always captured in full resolution and can then be displayed with any smoothing desired at any point in the future.

You can adjust the smoothing applied to traces in *Magnitude* and *Phase* plots via the in-plot smoothing control in the lower right corner of the plot. By default, the smoothing settings for *Magnitude* and *Phase* plots are linked, but you can un-link them in *Transfer Function Graph Settings* by de-selecting the *Link Phase & Mag Smoothing* checkbox.



Figure 33 - In-Plot Smoothing control

## CURSOR READOUT

One of the most important analysis tools in Smart is the mouse cursor. In addition to operating the programs' controls, the cursor is used to find precise values for any point of interest on any plot. When you position the cursor over any data in any plot, the Cursor Readout Area at the top of the graphing area displays information about the data under the cursor (amplitude, frequency, or time units depending on the data type).

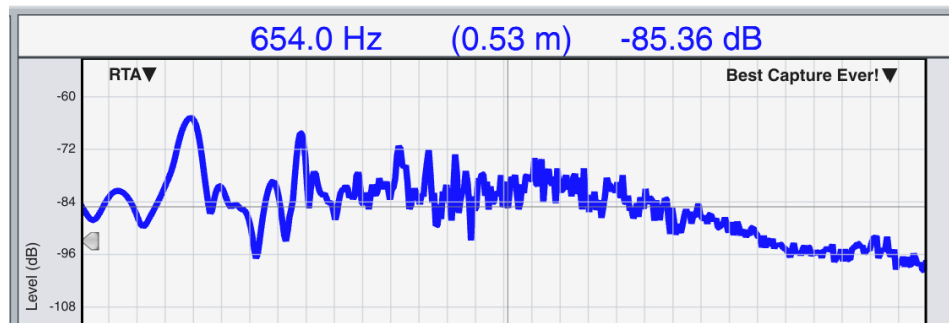

Figure 34 - Cursor Readout area, displaying Frequency, Wavelength and Magnitude for the data under the cursor

## CURSOR CONTROLS

### Cursor Data Tracking

Whenever the cursor is positioned within a plot, a “crosshair” appears with horizontal and vertical lines extending all the way across the plot. By default, this crosshair will follow the mouse cursor horizontally, and snap to the nearest data value on the vertical axis. If multiple traces are displayed, the cursor tracks the focused trace (at the top of the z-order). You can turn off data tracking for the moveable cursor by unchecking *Command > Cursor > Free Cursor Tracks Data* or via the hotkey [Ctrl/Cmd] + [Shift] + [F]. Additionally, this setting is accessible in the *Cursor* tab of the *Options > Preferences dialog*.

On spectrograph plots, the moveable cursor crosshair always moves freely in both the x and y axes.

### Locked Cursor

In addition to the moveable “free” cursor, you can also set a second cursor, called a “locked” cursor, in most plot types in Smart LE (the exceptions are *Spectrograph* plots and the *Live IR* pane). When a locked cursor is

present, the cursor readout area presents data for both cursors (locked and free) and also displays the difference between the two in brackets.

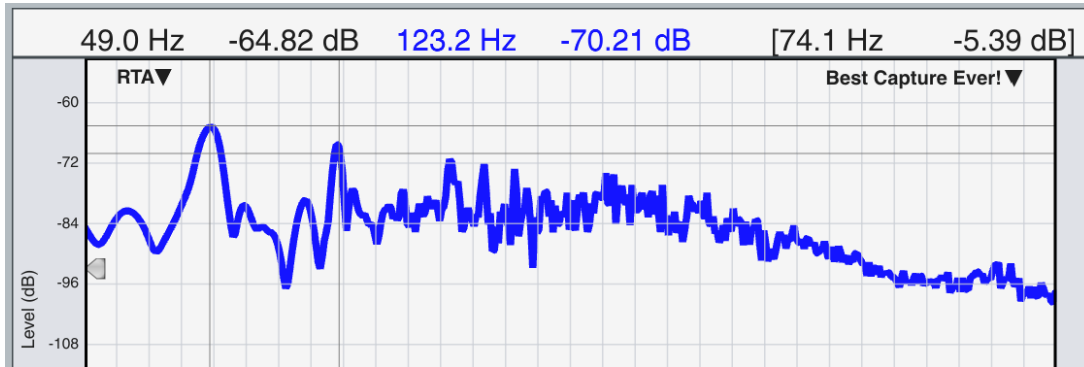

Figure 35 - Locked Cursor behavior. The Locked Cursor data appears in black, the Free Cursor data appears in blue to match the focused data, and the differential data appears in [brackets]

To set a locked cursor, hold [Ctrl/Cmd] and click at the location you'd like to set the cursor to. Alternatively, press [Ctrl/Cmd] + [P] or *Command > Cursor > Locked Cursor to Peak* to set a locked cursor at the highest peak in the focused trace. Remove the locked cursor via *Command > Cursor > Locked Cursor Clear* or the hotkey [Ctrl/Cmd] + [X].

The *Command > Cursor* menu also offers an option for *Locked Cursor Tracks Data*, which can also be toggled via the hotkey [Ctrl/Cmd] + [Shift] + [L]. This causes the locked cursor to track up and down to different amplitude / magnitude values at the same frequency as the data beneath it changes. Additionally, this setting is accessible in the *Cursor* tab of the *Options > Preferences dialog*.

## READOUT OPTIONS

Smaart LE offers several options to customize what information is displayed in the Cursor Readout Area. These settings are located in the *Cursor* tab of the *Options > Preferences dialog*.

The *Cursor Frequency Readout* setting controls what is displayed when the cursor is located in a frequency domain plot (*RTA*, *Spectrograph*, *Magnitude*, or *Phase*).

- *Frequency* displays *only* frequency in Hertz for the data under the cursor position
- *Frequency & Wavelength* displays frequency in Hertz and the corresponding wavelength in feet or meters, depending on the temperature and distance units selection specified in the *General* tab of the *Preferences dialog*
- *Frequency & Note ID* displays frequency in Hertz and the closest musical note corresponding to that frequency

The *Cursor Time Readout* setting controls what is displayed when the cursor is located in a time domain plot (*Live IR*).

- *Milliseconds* displays the time coordinates in milliseconds only
- *Milliseconds & Distance* displays the time coordinates as milliseconds and as equivalent distance, based on the *Speed of Sound* setting in the *General* tab of the *Preferences dialog*

- *Milliseconds & Samples* displays the time coordinates as milliseconds and equivalent number of samples based on the IO device's current sampling rate

## CAPTURING AND HANDLING DATA

### THE DATA BAR

The Data Bar, which resides along the left side of the program window, is dedicated to accessing and managing stored measurement data. The Data Bar is essentially a window into the Documents\Smaart LE\Data folder on your computer's hard drive where captured traces for the active plot type are stored.

You can hide or show the data bar by:

- Toggling the Data Bar entry in the *View* menu
- Clicking the corresponding button in the View flyout (first button in the second row)
- Using the hotkey [B]
- Clicking the *Data Bar* button which is assigned by default to the Command Bar

When the Data Bar is hidden, a disclosure arrow appears along the left side of the interface. Click the arrow to show the Data Bar.

The data bar shows only one type of stored data at a time – either stored spectrum data when a spectrum-type plot (*RTA* or *Spectrograph*) has focus, or transfer function data when a *Magnitude* or *Phase* plot has focus. The heading at the top of the data bar tells you which type of data files are currently shown.



Figure 36 - the Data Bar

Each stored trace visible in the data bar has an icon colored to match the display color for the trace data. An X appears over the icon for data that is not currently being displayed in a plot.

You can organize stored data in the data bar using folders and drag-and-drop operations much as you would in any file system window on your computer, and you can drag files and folders from the data bar onto a plot to display them.

There is always one folder “pinned” to the top of the Data Bar – this is the Session Folder, and it is the destination for any captured measurement data or new folders created during your measurement session. You can create a new session folder by clicking the three-line (hamburger) menu button at the top of the data bar and choosing *New Session Folder*. You can also drag an existing folder to the top position in the Data Bar to make it the new session folder. If you haven’t done this before, Smaart will pop up a messaging asking you if you wish to do so. Creating a new session folder automatically creates folders for both Spectrum and Transfer Function data, while changing the session folder via drag and drop only applies to the current data type.

At the bottom of the data bar are two buttons. The button with the Info icon is used to open the *Trace Info* dialog for a selected data file. See *Trace Info* on page 38. The button with the Trash Can icon will delete any selected files or folders and their contents. The deleted files will end up wherever deleted files go on your computer’s operating system, whether that’s the Trash for macOS or the Recycle Bin on Windows.

The three-line (“hamburger”) menu at the top of the data bar opens a menu with many commands for data management. See *Data Bar Menu* on page 47.

---

## CAPTURING DATA

At any time, you can capture data being produced by a measurement engine to store it in your data library. The most common way to capture data is by pressing [Spacebar], but you can also use the *Command > Stored Data Traces > Capture* or press the *Capture* button that appears by default on the Command Bar.

When *Capture* is executed, Smaart will capture the output of the measurement engine on the top of the z order in the active plot. A *Capture Trace* pop-up window will display a default name for the captured data based on the name of the measurement engine that generated it. Press *Enter* or click *OK* to keep the default name or type the name you wish and then press *Enter*. The saved trace will appear in your Session Folder inside the data bar.

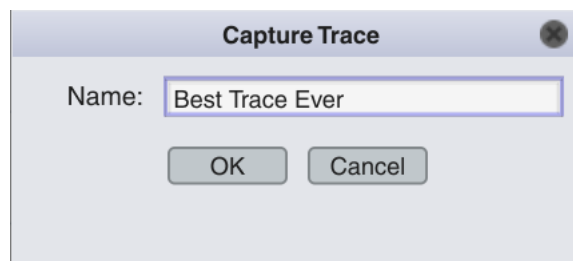

Figure 37 - Capture Trace dialog

Measurement data is always captured directly at full resolution, regardless of the current banding or smoothing settings, so that those parameters can be adjusted later without any changes to the raw underlying measurement data.

Note that the measurement data is captured at the time *Spacebar* is pressed – you can take as long as you like to name the trace, the measurement data has already been captured.

You can use a *Capture All* command ([Shift] + [Space]) to capture the output of all measurement engines that are running, visible in the Control Bar, and displaying data in a plot (not hidden). The *Capture All* command is also found in the *Command > Stored Data Traces* menu and is assigned to the Command Bar by default.

When a *Capture All* is executed, a *Capture Group* pop-up window will display a default name for the folder that will hold all the captured traces. Press *Enter* or click *OK* to keep the default name or type the name you wish and then press *Enter*. A folder with the desired name will be created in the Data Bar containing all the traces that were captured.

---

## DATA FOLDER STRUCTURE

Smaart LE produces two main types of stored measurement data - .srf files are saved Spectrum measurement data, and .trf files are saved Transfer Function measurement data. Inside the Documents\Smaart LE\Data folder, you will find folders labeled Spectrum and Transfer Function which hold captured .srf and .trf data, respectively. The Data Bar within Smaart is a “live view” of these two folders, so renaming or deleting a saved measurement inside the Data Bar will do so inside the Data folder as well. The converse is also true.

---

## DATA BAR MENU

Clicking the three-line (hamburger) menu at the top of the Data Bar opens a menu containing a number of data operations.

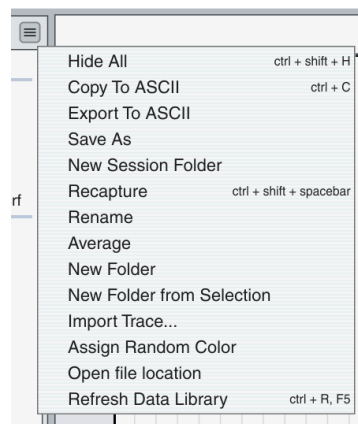

Figure 38 - Data Bar hamburger menu

*Hide All* hides all stored traces currently visible in the graph area.

*Copy to ASCII* copies the data from the selected stored data file to the operating system’s clipboard in tab-delimited ASCII text format, suitable for pasting into a spreadsheet, text editor, or any other program that accepts ASCII text. ASCII exports of spectrum data consist of three columns: frequency, magnitude, peak

magnitude (as dictated by the *Peak Hold* options in Spectrum Graph Settings) and column headers. ASCII exports of transfer function data include frequency, magnitude, phase and coherence plus column headers.

*Export to ASCII* exports the data from selected file(s) to tab-delimited ASCII text files. You will be prompted to choose or create a destination directory for the exported files.

*Save As* saves a copy of the selected trace to some location other than the Data Library. Selecting this command opens a *Save Trace As* dialog that will let you browse your computer's file system and select where you wish to store the data.

*New Session Folder* creates new session folders for both Spectrum and Transfer function files, to act as the destination for any newly captured measurement data. Selecting this command pops up a dialog box asking you for a Folder name. When you click *OK*, new session folders with the specified name are created in both the *Spectrum* and *Transfer Function* subdirectories of the Documents\Smaart LE\Data folder.

*Recapture* replaces the data in the selected trace data file with fresh measurement data captured from the focused live measurement engine in the focused plot.

*Rename* allows you to change the name of a selected file or folder in the data library. Press [Enter] to set the new name.

*Average* will allow you to create an average from stored data. See Averaging Stored Data.

*New Folder* creates a new empty folder inside your current session folder.

*New Folder from Selection* is enabled when one or more saved data files are selected. This command creates a new folder in the Session Folder and moves the selected items into it, after which the name of the new folder is automatically selected for editing so you can simply start typing to rename it. Remember to press [Enter] to set the change.

*Import Trace* does the same thing as *File > Import > Trace Data File*. It can be used to import stored data files from other locations on your computer into your Smaart data library, and can convert legacy .ref files from older versions of Smaart, Smaart Pro or SmaartLive into .srt or .trf files. Note that the Import Trace dialog only shows you trace files matching the current type shown in the Data Bar (Transfer Function or Spectrum). Legacy .ref files can be either type, so if you select a .ref file for import and nothing happens, try switching the focused plot type. Note also that Smaart cannot import legacy reference group .rgp files from Smaart Pro or SmaartLive, only individual .ref files.

*Assign Random Color* will give all selected traces a random trace color. If you don't like the results, you can run the operation again, or of course select a color you like in *Trace Info*.

*Open File Location* opens the folder where the selected data is stored on your computer's hard drive. This is useful for when you want to quickly copy saved measurement data to another location or sent it to a friend.

*Refresh Data Library* forces Smaart to re-read the contents of its data library folder. If you have made any changes to files or folders in the Data Library from outside of Smaart – for example, by sorting and renaming files using your operating system's file explorer – while Smaart is open, you can use the *Refresh Data Library* command to make sure Smaart picks up the changes.



## DATA BAR CONTEXT MENU

The context menu that appears when you right-click any file or folder in the Data Bar is mainly a sub-set of the commands detailed above, with two additional items: *Info* opens the Trace Info dialog for the selected data file (see Trace Info on page 38) and *Delete*, which will delete the selected folders and / or files, and behaves the same way as the delete function within your computer's operating system. The deleted files will end up wherever deleted files go on your computer's operating system, whether that's the Trash for macOS or the Recycle Bin on Windows.

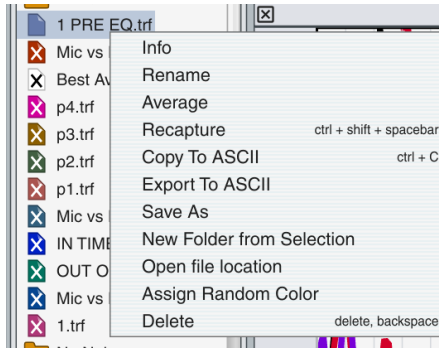

Figure 39 - Data Bar right-click menu

## AVERAGING STORED DATA

If a folder and/or multiple saved data files are selected, Smart will offer to average the selected traces, including all traces contained within any selected folder. To multi-select files and folders in the Data Library, you can hold down the [Ctrl/Cmd] key on your keyboard while clicking with your mouse, or hold down the [Shift] key to select a contiguous group of traces. If a single data file is selected or there is no selection, choosing *Average* will open the full version of the trace averaging dialog, where you can select individual trace files you wish to contribute to the average.

In either case, you can enter a name for the averaged trace in the *Name* field, and choose to use either decibel (*dB*) or *Power* averaging. In the case of transfer function averages, you have the additional option of applying *Coherence Weighting* to the average, and in the case of spectrum averages, you have the option of applying normalization. These are the same options available for live averages. See *Spatial Averaging* on page 76 for more information.

The *Color* field will allow you to choose the display color for the trace. Once you click *OK*, the new averaged trace data will immediately appear in your session folder in the data bar, and on the focused plot in the graphing area.

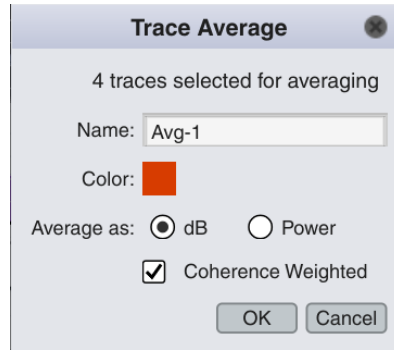

Figure 40 - Trace Average dialog

---

## IMPORTING AND EXPORTING DATA

You can import stored measurement data into Smaart by using the *Import Trace* function in the Data Bar hamburger menu, or *File > Import > Trace Data File*. It can be used to import stored data files from other locations on your computer into your Smaart data library, and can convert legacy .ref files from older versions of Smaart, Smaart Pro or SmaartLive into .srt or .trf files. Note that the Import Trace dialog only shows you trace files matching the current type shown in the Data Bar (Transfer Function or Spectrum). Legacy .ref files can be either type, so if you select a .ref file for import and nothing happens, try switching the focused plot type. Note also that Smaart cannot import legacy reference group .rgp files from Smaart Pro or SmaartLive, only individual .ref files.

Alternatively, you can simply use your operating system's file browser to place stored measurement data in the Documents\Smaart LE\Data folder, choosing the appropriate subfolder, either Spectrum or Transfer Function. This is a quick way to import large data sets and nested folders. If you are using your operating system's file browser to import or organize data while Smaart is open, you may wish to use the *Refresh Data Library* function in the Data Bar's hamburger menu to ensure that Smaart picks up on the changes.

Data export in Smaart LE is handled via the Data Bar hamburger menu, or by right-clicking on the saved trace data directly. There are several options available: *Copy to ASCII*, *Export to ASCII*, and *Save As*.

*Copy to ASCII* copies the data from the selected stored data file to the operating system's clipboard in tab-delimited ASCII text format, suitable for pasting into a spreadsheet, text editor, or any other program that accepts ASCII text. ASCII exports of spectrum data consist of three columns: frequency, magnitude, peak magnitude (as dictated by the *Peak Hold* options in Spectrum Graph Settings) and column headers. ASCII exports of transfer function data include frequency, magnitude, phase and coherence plus column headers.

*Export to ASCII* exports the data from selected file(s) to tab-delimited ASCII text files. You will be prompted to choose or create a destination directory for the exported files.

*Save As* saves a copy of the selected trace to some location other than the Data Library. Selecting this command opens a *Save Trace As* dialog that will let you browse your computer's file system and select where you wish to store the data.

Alternatively, you can simply use your operating system's file browser to locate stored measurement data for sharing to another computer. Stored measurement data is located in the *Documents\Smaart LE\Data* folder

on your computer. To open a file browser window directly to the data in question, right-click the stored data in the data bar and choose *Open File Location*.

## THE SIGNAL GENERATOR

The signal generator is the only component within Smaart LE that generates output signals. The signal generator can generate a variety of test signals and has a number of options. When the signal generator is activated, it will output the desired signal on all outputs on all devices that are currently selected in *Output Config*.

If you haven't selected any output device channels for use, the signal generator will display a popup message letting know that it couldn't start. Clicking the *Configure* button in this popup will bring you to the *Output* tab of *IO Config* to make your device and channel selections. See Initial Configuration – Selecting Outputs on page 17.

---

## CONTROL AREA

The Signal Generator controls inhabit the bottom row of the Control Bar, where a button labeled with the current signal type selection acts as the On / Off, and will glow red when the signal generator is running. You can also turn the generator on and off using the [G] hotkey. The + and – buttons adjust the generator level, which is displayed in the level field. Clicking within the level field opens the Signal Generator settings.



Figure 41 - Signal Generator control bar controls

---

## SIGNAL GENERATOR DIALOG

In the bottom left of the signal generator dialog is the *Output Config* button which will bring you to the *Output* tab of the *IO Config* dialog, so you can select output channels for the generator to use if you haven't done so already.

In the upper left of the signal generator dialog is a *Signal* drop down that allows you to select the type of signal. Choices are *Pink Noise*, *Sine*, *Dual Sine*, and *File*. Some of the available options displayed will vary depending on what signal type is selected.

*Stop Gen after Capture* turns the generator off as soon as a *Capture* or *Capture All* command is executed. This allows you to minimize the amount of time the generator is on by turning it off as soon as the required data has been acquired.

*Fade In* enables a gentle ramp up to the desired level each time the generator is turned on.

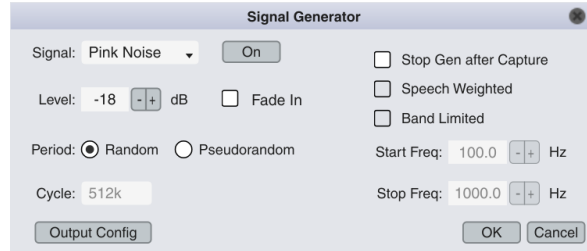

Figure 42 - Signal Generator dialog

Signal levels for all generator output signals are displayed relative to normalized full scale peak, meaning that the maximum possible amplitude value is 0 dBFS.

---

## SIGNAL TYPES

### PINK NOISE

Smaart can generate two basic types of pink noise, which we refer to as *Random* and *Pseudorandom*. *Random* pink noise is created by streaming the output of a random number generator through a digital filter network, much the same way that most hardware pink noise generators work.

Pseudorandom noise signals in Smaart repeat on intervals that are power-of-two samples in length up to  $2^{19}$  (512K samples)<sup>1</sup>. Although both random and pseudorandom noise will give effectively comparable results for the general real-time transfer function measurements produced by Smaart LE, pseudorandom noise has some mathematical advantages when dealing with more advanced measurement features such as sync-source measurement found in other versions of Smaart. However, pseudorandom noise also offers the advantage that it can be band-limited to fit a specific measurement application.

When measuring with pseudorandom noise, you should always select a cycle length that is at least as long as the longest FFT time constant used in your measurement. Since the longest time constant used in MTW is approximately 1 second, 64K would be the lower limit at 48 kHz sample rate. However, it repeats so often that it may become annoying to listen to. For real-time measurements in general, a setting of 512K or 1024K is generally a good choice.

There are three spectral options for pseudorandom noise: broadband pink noise, band-limited pink noise, and speech weighted noise. Pink noise has a spectrum that appears flat on an *RTA* using fractional octave banding, and rolls off at 3 dB per octave / 10 dB per decade on an un-banded display. Bandlimited pink noise has the same nominal spectrum across a specified bandwidth. Checking the *Band Limited* option enables the *Start Freq* and *Stop Freq* controls, enabling you to specify your desired passband.

---

<sup>1</sup> Technically, the random number generator is pseudorandom also, however, given its length of  $2^{19937}$  samples it will effectively never repeat.

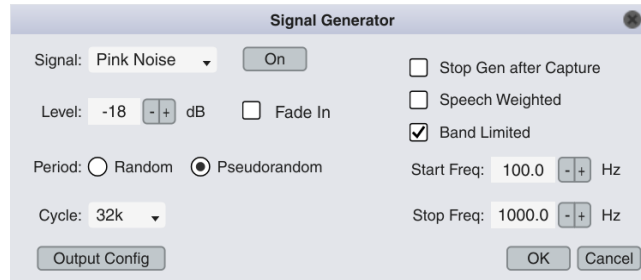

Figure 43 - Signal Generator dialog showing Pseudorandom Pink Noise controls

*Speech Weighted* noise is pseudorandom noise with a spectral shape based on the idealized long-term idealized average speech spectrum (LTASS) defined in ANSI S3.5-1997.

All noise signals are calibrated to normalized full scale, which means the maximum possible amplitude value is 0 dBFS. Random and pseudorandom noise signals are hard limited to ensure a peak-to-RMS ratio of 12 dB.

## SINE AND DUAL SINE

The options for *Sine* signals and *Dual Sine* signals are essentially identical. Selecting *Sine* just removes the bottom row of controls that is visible when *Dual Sine* is selected. The relative signal level for each tone (*Level 1* and *Level 2*) is set independently, and the master Level control controls the overall signal level.

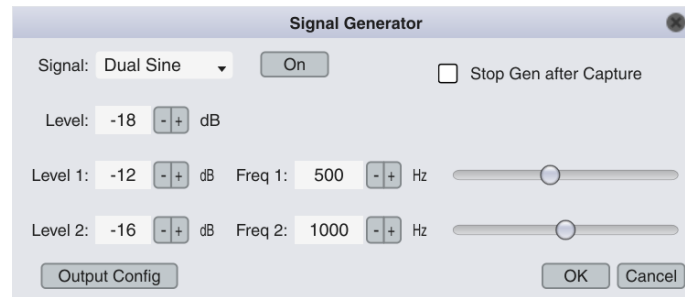

Figure 44 - Signal Generator dialog showing Sine and Dual Sine controls

Signal levels for all generator output signals are displayed relative to normalized full scale peak, meaning that the maximum possible amplitude value is 0 dBFS, and the maximum RMS level would be  $-3$  dBFS.

## FILE

*File* allows you to use any .wav or .aiff file as a test signal. When using file-based signals, simply specify the file you wish to use by clicking the *Browse* button and then specify the output level. When *Normalize* is selected, Smart will scale the signal to a peak level of 0 dB normalized full scale. Note that the signal is sent identically to all outputs. If the source file is stereo, only the left channel is used, and the right channel is ignored. Also, be aware that Smart copies the entire file into RAM to provide seamless lopping, so you may want to keep the file lengths fairly short.

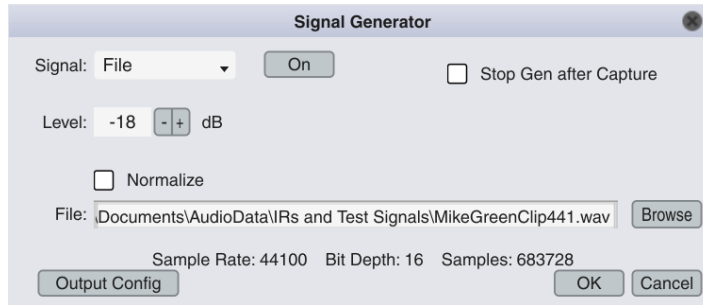

Figure 45 - Signal Generator dialog showing File controls

## SKINS

Smaart has two built-in color schemes, the *Default Dark* scheme that you see the first time you run the program, and a *Default Light* scheme that uses dark text against a lighter background. *Default Dark* works well indoors, particularly in darkened rooms. *Default Light* might be a better choice in brightly lit environments, or when making screenshots for printed documents or presentations.

You can change between them using the *View > Skins* menu, cycle through all available skins using the hotkey [Ctrl/Command] + [Shift] + [X].

In addition to the built-in defaults, Smaart also allows you to define custom color schemes (“skins”) via the *Skins* tab of the *Options > Preferences* dialog.

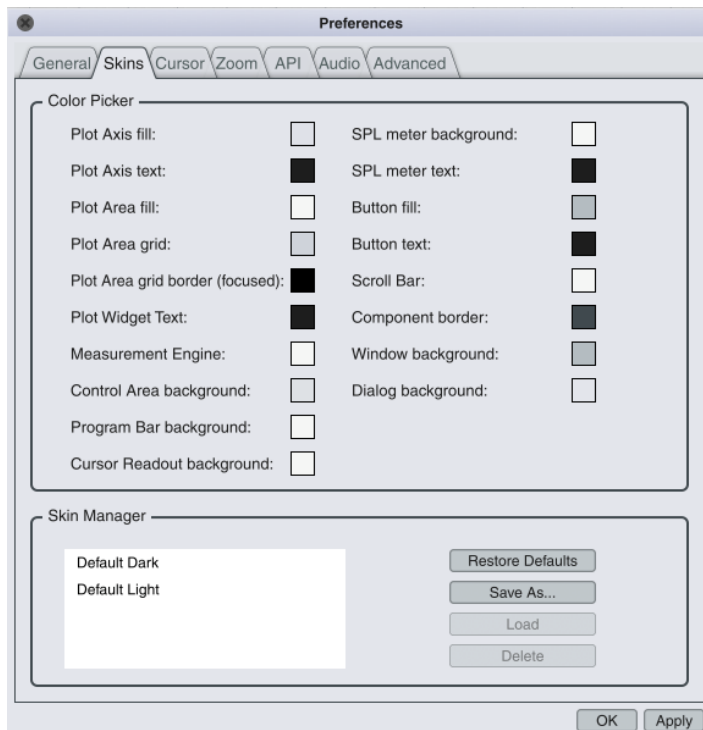

Figure 46 - Skins Preferences

The *Skins* tab is divided into two sections, *Color Picker* and *Skin Manager*. The *Color Picker* section consists of color tiles showing the color assignments for various interface elements in the current color scheme. Each

color tile is a button that opens a *Color Selection* dialog. Color changes take effect immediately when you click *Apply* in the color selector.

The *Skin Manger* section lists all available color schemes. Since the *Default Light* and *Default Dark* skins can't be altered, making a change while one of them is the active skin will create a *New Custom Skin* using either the *Default Light* or *Default Dark* skin as a starting point. You can rename a custom skin by double-clicking it in the list and typing a new name. Custom skins update with any changes in real time. The *Restore Defaults* button will restore all colors in the custom skin to match either the *Default Light* or *Default Dark* skin on which it was based. *Save As* will save a copy of the skin with a new name. *Load* will select a skin for use, and *Delete* will delete the custom skin.

Custom skins are stored in the *Documents\Smaart LE\Skins* directory as .xml files, so you can move them to other computers or share them with friends by placing the files in this folder.

## INPUT METERS

Smaart's *Input Meters* dialog is accessible via *View > Input Meters* or [Shift] + [E]. The dialog displays an input meter for each input that is selected for use in the *Input* tab of *IO Config*. The device and input Friendly Name are displayed for each, along with a polarity invert button. If the IO device supports Smaart's gain tracking feature (Roland OctaCapture and Audient EVO series), additional controls are displayed for phantom power and preamp gain.

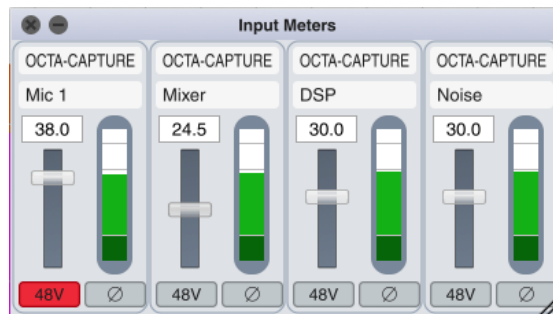

Figure 47 - Input Meters, showing additional gain and +48V controls available when using Roland OctaCapture or Audient EVO hardware

You can toggle the orientation of the input meters between vertical and horizontal via *View > Input Meters Orientation* or [Shift] + [Alt/Option] + [E].

## API

Smaart LE includes an API which allows the sharing of real time measurement data to third-party programs and devices, such as system processors and filter design software programs. In *Options > Preferences > API*, you can click the *Enabled* checkbox to start the API running and make Smaart's measurement engine data streams available at the IP / Hostname / Port specified in the settings. The *Status* indicator turns green to indicate the API is running.

**ADVANCED SETTINGS**

In Smaart LE, a single setting is available in the *Options > Preferences > Advanced* tab. *Allow Multi-Device TF* enables you to select your measurement and reference channels from different input devices when configuring transfer function measurement engines. Although this is sometimes helpful in specialized situations, it is generally best avoided, as measuring across devices can cause clock drift in the measurement, which can render phase, Live IR data and measurement delay times useable. If your application requires multi-device transfer function measurement, you may wish to contact Rational Acoustics support for assistance.



## 4 – FUNDAMENTAL MEASUREMENT CONCEPTS

In this section you will find an overview of the fundamental measurement concepts that are critical to the fruitful operation of Smaart in the field. While we strive to provide a functional level of context, the reader is encouraged to supplement their study of these topics with additional works dedicated to measurement and analysis. A list of recommended resources is found in the Appendix.

### QUESTIONS AND VIEWPOINTS

Conceptually, a measurement provides an answer to a question. The nature of the question being asked will dictate choice of measurement and workflow. Thus, the first step in a fruitful measurement process is to clarify for yourself the question that you're asking. A conceptual understanding of the measurement tools available in Smaart will be your guide.

---

### SIGNAL ANALYSIS VS SYSTEM RESPONSE ANALYSIS: SINGLE VS DUAL CHANNEL MEASUREMENTS

All measurements taken with Smaart fall into two broad categories: single-channel (signal analysis) and dual-channel (response analysis). Understanding the differences between the two, and when to use each type of measurement, is of paramount importance to using Smaart effectively. Both single- and dual-channel measurements are powerful tools when applied properly. Conflating or confusing the two, however, can lead to poor decisions based on incomplete or incorrect information.

---

#### WHY ARE THEY USED? WHAT DO THEY TELL US?

Single-channel measurements ask the conceptual question “What do we have?” In the simplest terms, they display information about a signal, hence the term “signal analysis”. Spectrum measurements are signal analysis measurements because they simply display the frequency content of a signal. In Smaart, Real-Time Analyzer (RTA) and Spectrograph displays are created with single-channel FFT analysis.

Another type of single-channel measurement in Smaart LE is sound pressure level (SPL) measurement. When using a calibrated measurement setup, SPL measurements can tell us about the sound levels that are occurring at a point in space (wherever the measurement microphone is located).

A good rule of thumb is that we should use single-channel measurements to answer questions about the properties of a signal itself. We might use a single-channel measurement to investigate “How much 1 kHz energy is in that signal,” “what is the frequency of that feedback tone,” or “what is the sound level at this position in the venue?”

Dual-channel measurements, by contrast to signal channel measurements, are *comparative* measurements. They compare two signals to find the similarities and differences between them. In Smaart LE, **transfer function** measurements are dual-channel measurements that are used to compare the output signal of a device or system to the input signal that produced it. Dual-channel measurements therefore ask the conceptual question “what effect does this device or system have on the signals passing through it?”

Since we know what went in and what came out, we can determine what happened in between – and also *when*. Transfer function measurements allow us to precisely measure time relationships between the two signals, enabling us to examine phase relationships and find delay times for signal moving through systems.

We use the term “measurement signal” to refer to the signal that appears at the system’s output, and the term “reference signal” to refer to the signal that was sent into the system – acting as the basis for comparison, hence the term “reference.” The transfer function measurement then displays the results of this comparison in a variety of ways.

A good rule of thumb is that we should use dual-channel measurements to answer questions about the response of a system, or in other words, to study how a system affects the signals passing through it. We might use a dual-channel measurement to investigate “What is the crossover frequency of this system”, “How much attenuation is this equalizer providing at 1 kHz,” or “What is the latency of this processor?”

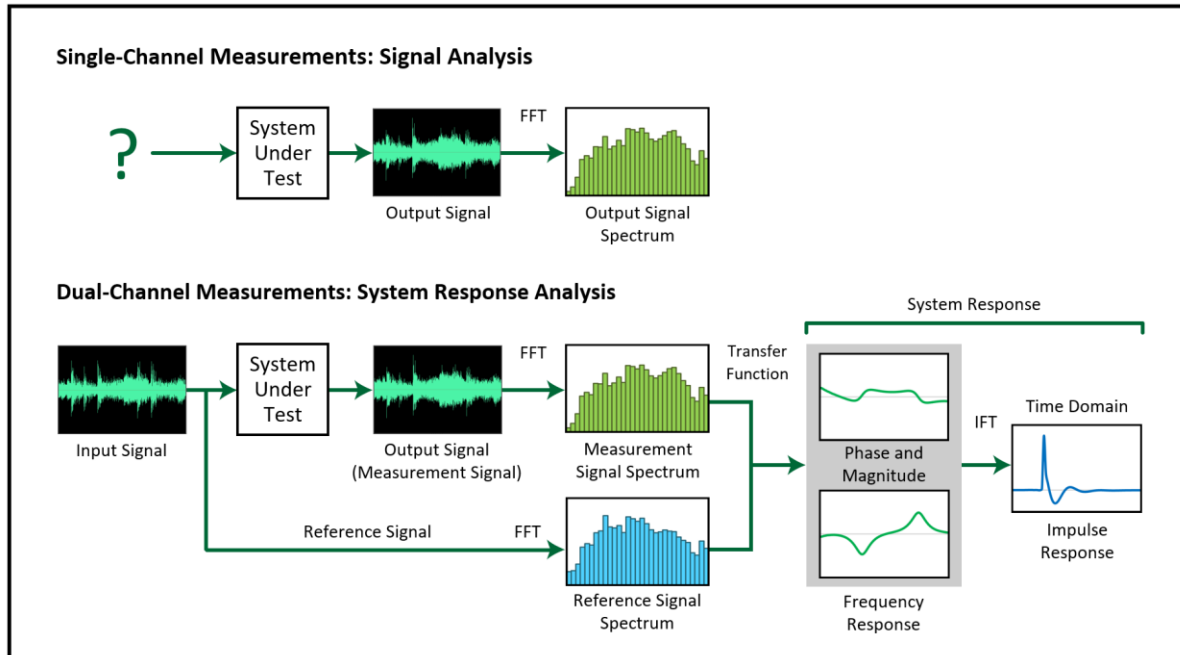

Figure 48 - Single-Channel vs Dual-Channel measurement

## TIME DOMAIN VS FREQUENCY DOMAIN ANALYSIS

The “domain” of a graph refers to the independent variable, or conceptually, the context in which the signal is occurring. For example, an audio waveform is a time-domain signal, because the signal level (be it voltage, digital amplitude, or sound pressure) varies over time. If we wanted to make a graph of the audio waveform, we would normally put time on the horizontal ( $x$ ) axis and amplitude on the vertical ( $y$ ) axis.

Frequency domain analysis of a signal, on the other hand, shows the energy content of the signal over frequency. In this case, we usually put frequency on the horizontal ( $x$ ) axis and signal level on the vertical ( $y$ ) axis.

In Smaart, we can study both signals and system response (single- and dual-channel measurement data) in both the time and frequency domains simultaneously. The ability to see both representations at once is key to maximizing our understanding what we are measuring.

WHY ARE THEY USED? WHAT DO THEY TELL US?

When an audio signal (time domain) is transformed into the frequency domain, we can view the spectrum of that signal, or in other words, its energy content over frequency. This is helpful, for example, when examining the tonal content of a mix or identifying feedback frequencies.

In sound system analysis, a time domain view of a sound system’s response (known as the *impulse response*) shows the arrival time of energy passing through the system, including any reflections and reverberation that might be problematic. System response in the frequency domain (*transfer function*) shows us the tonal response of the system (*magnitude trace*) and the phase relationship over frequency (*phase trace*), which taken together allow us to learn how the system will affect the signals passing through it. We’ll discuss how to read and interpret system response measurement data in a following section.

THE MEASUREMENT “FOUR SQUARE”

We can now classify all measurements produced by Smaart two different ways – a measurement is either single channel or dual channel, and its data can be displayed either in the time domain or the frequency domain. The figure below illustrates this classification: the top row shows single-channel (signal analysis) in both time domain (waveform, left column) and frequency domain (spectrum, right column). The bottom row is similar but shows a system response measurement in the time domain (impulse response, left column) and frequency domain (transfer function, right column).

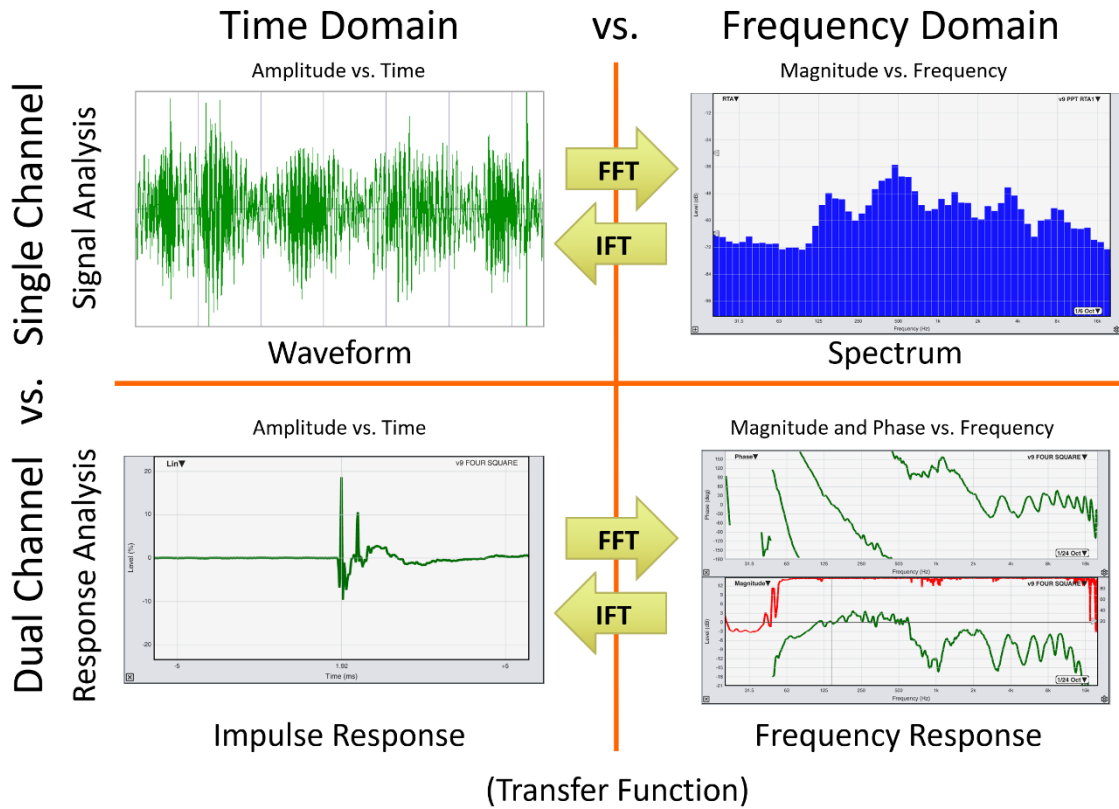

Figure 49 - The measurement "four square", showing time domain in the left column and frequency domain in the right column. Single-channel in the top row and dual channel in the bottom row

## BROADBAND VS BANDLIMITED

Broadband measurements are a look at the entire bandwidth of the captured signal – the overall level in the time domain, which corresponds to having the full spectrum of data available in the frequency domain. However, in some cases it is useful to apply band-limiting to a measurement, which allows us to focus on energy in a particular frequency range. For example, when working with Impulse Response measurements, Smaart provides the ability to apply a band-limiting filter to the impulse response data, which can allow us to discern the arrival time and overall time-domain behavior of energy in a certain frequency band.

Another example of band-limited measurements is the ability to measure SPL in octave bands, which offers a more granular look at sound pressure level information over frequency than the traditional broadband weightings.

## SPL / BROADBAND METERS

There are several places throughout Smaart’s interface – named, input configuration and measurement engines – where meters display the incoming digital signal level in dBFS. Signal levels below -60 dBFS are shown in dark green, transitioning to lighter green between -60 and -12 dBFS, then yellow from -12 to -6 dBFS and red above -6. Since the meters are calibrated to normalized full scale peak, the maximum possible level is 0 dBFS. If a clip is detected on any input channel, the entire meter will turn red until the overload condition is resolved.

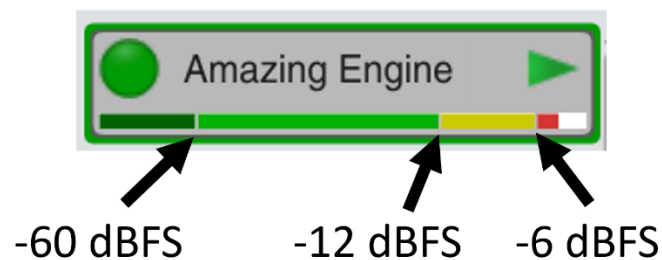

Figure 50 - Input meter with color key

At the top of the Control Bar, there is a docked level meter, which can instead display a clock. Any input that has been selected for use within Smaart can be selected from the dropdown menu and its level in dBFS displayed on the meter. For inputs that have been calibrated for SPL measurement, an additional selection of sound level metrics can be chosen as well.

## THE FOURIER TRANSFORM – THE ENGINE THAT POWERS THE ANALYZER

At the heart of modern audio analysis lies the Fourier transform, a set of mathematical operations that are used to transform audio signals between the time domain and frequency domain.<sup>2</sup> The Fourier transform is named for 19<sup>th</sup> century French mathematician and physicist Jean-Baptiste Joseph Fourier, and is based on the idea that complex signals (such as music or speech) can be mathematically “deconstructed” and broken down into their component frequencies – sine waves of varying levels and time relationships (magnitude and phase). In Smaart, Fourier transforms are used to calculate and display the spectral content of time domain signals.

<sup>2</sup> Of course, Fourier transforms are also used in many applications outside of audio, such as image processing.

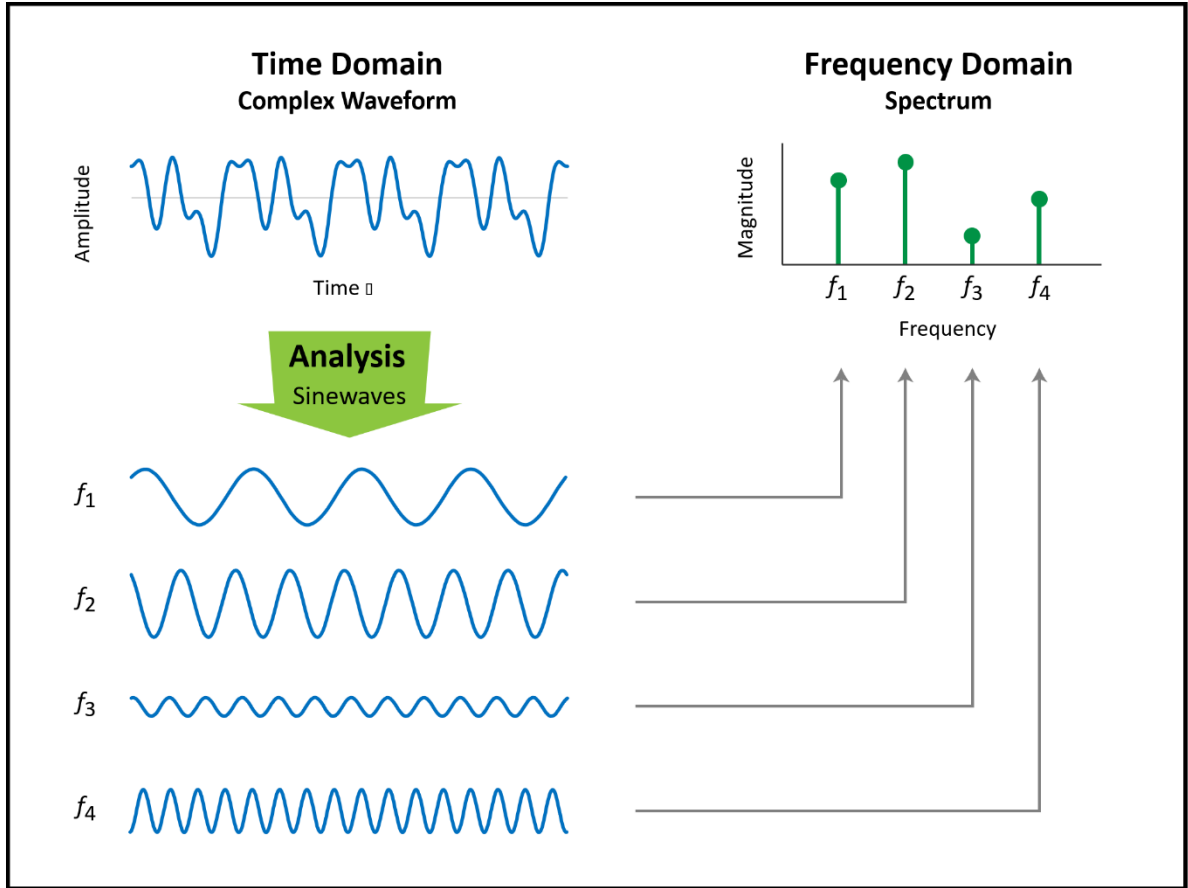

Figure 51 - a conceptual representation of the Fourier Transform, which breaks a complex time domain signal into its frequency components

### TIME-FREQUENCY RELATIONSHIPS

Working with discrete Fourier transforms (DFT or FFT) involves a key tradeoff that centers around the size of the FFT. The “chunk” of signal that gets fed into the transform is called the Time Record, or Time Constant, or Time Window. Using a longer time record increases the frequency resolution of the measurement, and allows the measurement to accurately resolve lower frequencies, but this comes at the cost of time resolution – all the signal’s energy within the time record gets “lumped together,” leaving us unable to distinguish between multiple events such as musical notes or syllables that might occur within the same time record.

We might decide to use smaller FFTs to increase time resolution and see individual rhythmic events, but this decreases frequency resolution, making it harder to resolve individual musical pitches, and so forth. This mathematical relationship can be elegantly described with the formula  $T = 1/f$  where  $T$  is time in seconds and  $f$  is frequency in Hz or cycles per second.

$$\text{Time Constant} = \frac{\text{FFT Size}}{\text{Sample Rate}} = \frac{1}{\text{Frequency Resolution}}$$

If desired, this formula can be rearranged for frequency resolution.

$$\text{Time Constant} = \frac{\text{FFT Size}}{\text{Sample Rate}} = \frac{1}{\text{Frequency Resolution}}$$

For example, let's say we want to perform an FFT on a time-domain signal so we can study its spectrum. If we use a 16K FFT (the default for spectrum measurements in Smaart), and our sample rate is 48 kHz, it will take about 341 milliseconds to acquire those 16,384 samples ( $16384/48000 = 0.341\bar{3}$ ).

Both the lowest frequency data point and the spacing of the frequency data points are dictated by the fact that our FFT has a time record of 341 milliseconds.  $T = 1/f$  tells us that our first data point ("bin") will be at a frequency of about 2.9 Hz ( $1/0.341\bar{3}$ ), and that frequency bins will be spaced about every 2.9 Hz. (The second data point will be at approximately 5.8 Hz, the third at approximately 8.9 Hz, and so forth.) If we want to increase our frequency resolution, and extend it to lower frequencies, we need to use a longer time constant (larger FFT).

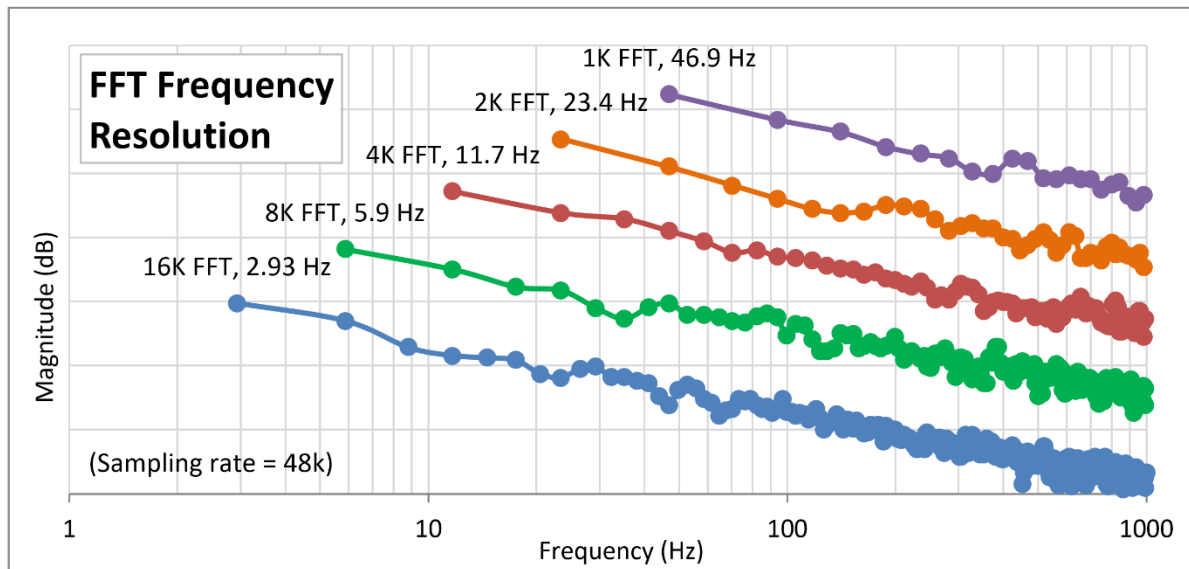

Figure 52 - the relationship between FFT size and frequency resolution

## DFT, FFT AND IFT

DFTs are somewhat computationally intensive, but in 1965, a new method for more efficient calculation, called the fast Fourier transform (FFT), made it possible to calculate the transform very quickly.<sup>3</sup> This paved the way for modern audio analysis, in which a typical laptop computer can continuously calculate multiple FFTs and display the results to the user in real time. The FFT commonly requires the "chunk" of signal being analyzed to contain a number of samples equal to a power of 2, for example, 4096 ("4K"), 8192 ("8K"), 16384 ("16K") and so forth.

<sup>3</sup> The FFT is commonly attributed to James W. Cooley and John W. Tukey's 1965 paper "An algorithm for the machine calculation of complex Fourier Series." Though the method had been discovered years earlier by mathematicians including Karl Gauss, it wasn't practical to execute until the advent of modern computers.

The Inverse Fourier transform (IFT) – is used to reconstruct time-domain signals from spectral data. This bidirectional relationship between time and frequency domains allows a wide range of possibilities for signal processing and analysis, since the signal can be transformed, processed and displayed in whichever domain is more helpful given the task at hand, and what we are hoping to learn from the measurement.

---

## COMPLEX DATA

The DFT and FFT mathematics take in a discrete time domain signal and produce a series of complex data points in the frequency domain. Complex data means that each frequency data point (“bin”) is described by a *pair* of numerical values, or complex coordinates. Termed “real” and “imaginary”, the pair of coordinates can indicate a location on a two-dimensional plane such as a graph or a map.

Complex coordinates can be stated as *rectangular coordinates* or as *polar coordinates*. Rectangular coordinates indicate the data point in an (X,Y) format, and is familiar to anyone who has done some graphing in math class. Alternatively, the same data point can be indicated in *polar* format as a vector, with one number indicating the distance from the reference point (*Magnitude*), and the other indicating the angle of rotation (*Phase*). Since we graph the magnitude and phase data on two separate plots, it might appear that they are two unrelated quantities, but in reality they are each telling us *half* of the entire mathematical reality, which is described by the combination of both the Magnitude and Phase data at each frequency.

When we look at spectrum data on an RTA or Spectrograph plot, we are seeing the *magnitude* half of the complex data, with no indication of phase. When a dual-channel measurement is produced, the complex data in the measurement and reference signals is compared to produce the *relative phase* data that forms the basis for the phase trace displayed in Smaart.

## SPECTRUM MEASUREMENTS (SINGLE CHANNEL)

Spectrum measurements produce information about the energy distribution in a signal – that is, which frequencies are present in the signal, and at what levels. Spectrum measurements are useful when we want to study a signal’s tonality, identify resonances and feedback, or want a visual confirmation of what we’re hearing at a location. In Smaart, the *RTA* and *Spectrograph* plots are both spectrum measurements.

---

## RTA

The real-time spectrum analyzer, or *RTA*, is a familiar tool to most audio professionals and probably needs little introduction. It enables you to see frequency content of signals moment-by-moment in real time. Essentially, the *RTA* is a graph of the energy in an incoming signal, broken down by frequency or frequency ranges, with frequency in Hertz on the x axis and magnitude on the y axis in decibels. The graph is updated continuously whenever at least one spectrum engine is running, to produce a real-time display. By adjusting the scale and averaging of the display, we can refine the “look and feel” or responsiveness of the measurement to suit different tasks. The *RTA* is the audio measurement that most closely corresponds with the human hearing mechanism, which explains its near omnipresence at mix position at live events.

### [Banding](#)

---

Fractional octave banding aggregates all the data points within a given bandwidth (one octave wide, 1/3 octave wide, 1/12 octave wide, etc) into a single level for that band. Banding can serve to illuminate overall

trends in the data, and, when displayed on a logarithmic frequency axis, produces a display that “looks like it sounds.” In other words, the fractional octave banding correlates better with human hearing perception.

Banding is a display parameter for spectrum measurements, not an inherent part of the underlying measurement data. Spectrum measurement data is always calculated, captured and stored at the original FFT resolution, and the banding can be changed after the fact without altering the stored measurement data.

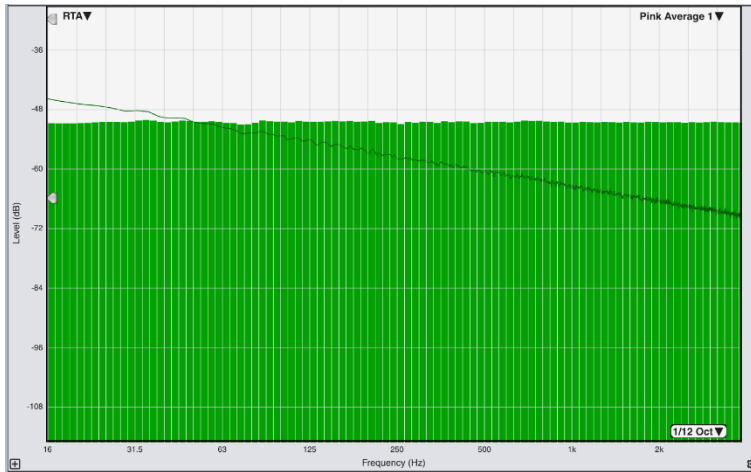

Figure 53 - Fractional-octave banding vs raw FFT data on a logarithmic frequency scale. The lighter green bars show the 1/12 octave banded RTA measurement of pink noise. The darker green line shows the un-banded view of the same data. The banding is what makes the pink noise appear “flat”

## SPECTROGRAPH

Smart’s spectrograph straddles the time and frequency domains, offering a view of how the frequency content of a signal changes over time. The spectrograph expands upon the utility of the RTA by displaying a scrolling display of continuous spectrum measurement “slices”. You can think of it like a “top down” view of the RTA, where the color indicates the height of each bar. In the realtime mode spectrograph, frequency is across the horizontal (x) axis, time scrolls vertically (y axis), and level is indicated by color. In Impulse Response mode, the horizontal (x) axis indicates time, as is true for the other Impulse Response plot types where time runs from left to right. Frequency is on the vertical (y) axis and level is indicated by color.

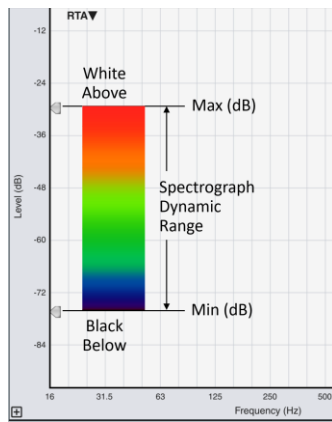

Figure 54 - Spectrograph Dynamic Range control widgets



## THE TRANSFER FUNCTION (DUAL CHANNEL)

The transfer function measurement is a dual-channel measurement that is created by comparing the output signal of a device or system to the input signal that produced it. Dual-channel measurements therefore allow us to study how a device or system affects signals that pass through it.

The two inputs that are compared to produce the transfer function measurement are called the Reference Signal and the Measurement Signal. The reference signal is the signal that is sent into the system as the basis for comparison, while the measurement signal is captured at the output of the system. An FFT is then performed on both the measurement and reference signals, and the resulting complex data is used to generate the views of the system response.

---

## THE VIEWS OF THE SYSTEM RESPONSE

The system response can be described and displayed in a number of ways, each providing unique insight. Taken together, we receive a wholistic understanding of the system under test. There are four components to a transfer function measurement displayed in Smaart: Magnitude, Phase, Coherence, and Live IR.

---

### MAGNITUDE

The transfer function Magnitude graph shows relative gain and attenuation in the response of the system under test at each frequency. If the reference and measurement signals are identical in level at all frequencies, the magnitude trace is a flat line at 0 dB. If there is an overall level difference between the two signals, that flat trace will move up or down on the graph. Up means the measurement signal is coming in at a higher level than the reference signal (system output higher than system input), and down means the opposite. If the system under test (SUT) produces relative gain at some frequencies and relative attenuation at others (as is the case with real world sound systems, equalizers, and so forth), the magnitude trace will deviate above the centerline of the measurement at frequencies where there is a relative gain, and dip below it in the regions of attenuation.

---

### PHASE

The transfer function *Phase* graph shows the phase portion of the frequency response of the system under test (SUT). Phase is plotted with frequency in Hertz on the x axis and phase in degrees on the y axis. Phase, or phase shift, is a measure of the relative time relationship between two signals as a function of frequency, expressed in terms of cycle time. Like the *Magnitude* plot, the slope of the phase trace is flat when the reference and measurement signals are identical and arrive at exactly the same time.

With a few exceptions, the key to reading the phase trace is not to focus on the degree values themselves, but instead to pay attention to the *slope* of the trace.

- When the phase trace slopes upward, energy in the measurement signal is arriving before energy in the reference signal.
- When the phase trace flattens out, that represents that the two signals are arriving at the same time.
- When the phase trace slopes downwards, energy in the measurement signal is arriving after energy in the reference signal.

If you simply remember and internalize these three simple points, you will be able to easily decipher phase data in the field.

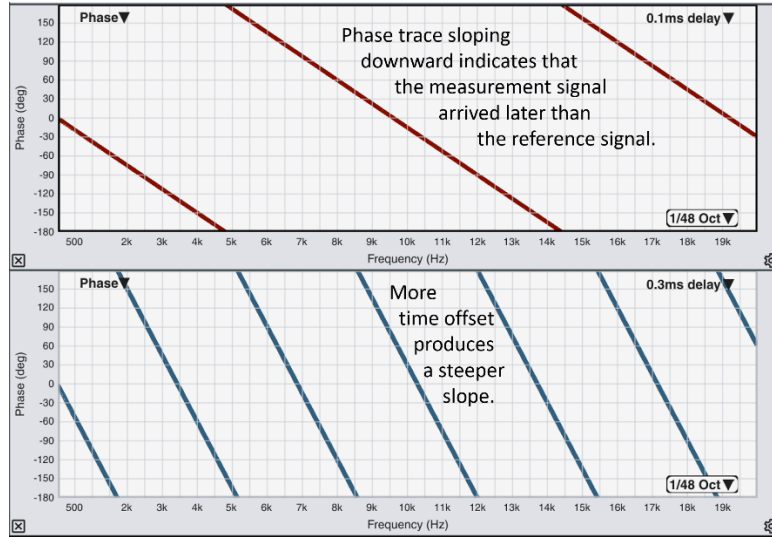

Figure 55 - Uniform (linear) delay on a linear frequency scale.

When there is a uniform time offset between otherwise identical signals (perhaps measuring a digital processor that is set to bypass, so it simply reproduces the input signal at unity gain after a brief processing delay), the phase trace is a straight line on a linear frequency scale. When it is sloping upward or downward at a constant rate of change, steeper slopes correspond to greater time offsets.

On a logarithmic frequency scale, the straight line becomes a curve and the wraps become more tightly packed as you ascend in frequency, but the information is the same.

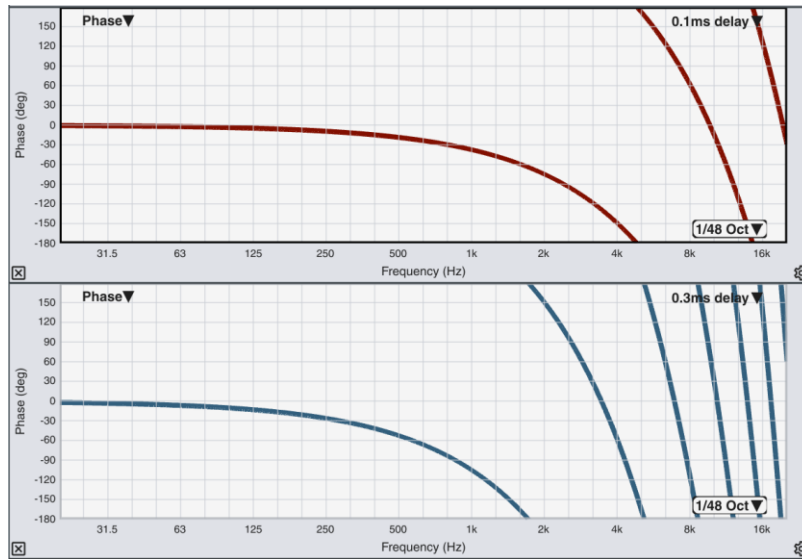

Figure 56 - the same phase traces shown on a logarithmic frequency axis

The phase trace “wraps” – that is, runs off the top or bottom of the graph periodically and reappears on the opposite side – because we are viewing cyclical data that spans 360° on a flat graph, so we have to have an edge somewhere (not unlike how a map of the world has to have an edge somewhere).

If you imagine cutting out the phase graph and gluing it to a paper towel tube, you will see that the phase data is inherently cyclical in nature. We cut the tube somewhere and flatten out the plot so we can read it. Out of convention, we split the plot along the 180° line, so 0° spans the centerline of the plot and 180° is at the top and bottom edge. If you click in the phase plot and use the Up and Down arrow keys on your keyboard, you can “roll” the phase trace to see its cyclical nature. This would be like taping the paper tube back together and slicing it at a different point.

Conceptually, the phase trace is like a clock that only has a second hand. Such a clock can’t directly tell us how many minutes have elapsed, but we can discern that information by counting how many times the second hand sweeps around. In the same way, we can’t discern time offset by looking at the phase value at any single frequency. By looking at the relationship between multiple data points – the *slope of the line* – we can begin to see the telltale signs of time offset.

For example, let’s say our measurement and reference signals are offset in time by 25 milliseconds. At 20 Hz, that 25 millisecond offset corresponds to half a cycle (180°). At 40 Hz, the same time offset corresponds to a full cycle (360°), but 80 Hz, 160 Hz, 320 Hz, and other multiple frequencies also complete full cycles in that amount of time. Since our phase trace only spans a 360° interval (-180° to 180°), we could expect any frequency that has completed one or more complete cycles to have a value of 0°. The phase trace would therefore be wrapped (the telltale indicator of time offset) and pass through 0° at 80 Hz, 160 Hz, 320 Hz, and so forth. We have much more useful information from looking at the entire trend of the trace than by trying to look at individual data points.

Up until now, we have been discussing phase shift in terms of two otherwise identical signals arriving at different times, but of course most things that we measure with Smaart do more to an input signal than simply delaying it. When audio signals flow through the System Under Test, they are typically filtered in some way – that is, the resulting signal will have more energy than the input signal at some frequencies, and less at others. You can think of transducers, loudspeakers, and even entire sound systems as bandpass filters. All of these devices allow energy that falls within some frequency range to pass, while energy outside that range is significantly attenuated.

In physical systems, any process that affects the spectral content of a signal also affects its timing. In other words, you cannot change magnitude response without also changing phase response.<sup>4</sup>

With the sole exception of symmetrical FIR filters, we can expect that all analog and digital filters, along with any other process that affects the frequency content of a signal, such as air loss or acoustical reflection – to produce an asymmetric impulse response. That is, they all affect the timing of the signal differently at different frequencies. The phase response of a bandpass filter, for example, typically leads at some frequencies, lags at others, and is in-time in between, so when you need to align two bandpass filters in a system – whether it’s two drivers, two cabinets, or two entire subsystems – there probably won’t be any single right answer that works at all frequencies. You’ll have to choose a frequency range where you want the two systems to align, which is where the phase display comes in handy.

---

<sup>4</sup> At this point, astute readers may wonder how linear-phase FIR filtering fits into this puzzle. No laws of the universe have been violated, however, and  $T = 1/f$  remains in effect: changing the signal in the frequency domain has an effect in the time domain as well – in the form of delay. Linear-phase FIR filters are designed with a symmetrical impulse response that induces the same amount of phase shift forward and backward, so the phase shift in the back half of the filter effectively cancels out the phase shift in the front half. The price to be paid is an overall delay time as the IR peak is shifted back in time, which limits the applicability of FIR filters in live sound reinforcement environments, particularly at low frequencies.

## COHERENCE

Coherence is a statistical evaluation of the causality or linearity between the reference and measurement signals in a transfer function measurement. You can think of it as a data quality indicator. Coherence can detect contamination of the measurement signal by unrelated signals such as background noise or reverberation, and it is sensitive to timing mismatches as well. We use it in Smaart to gauge the quality of transfer function measurement data for every frequency data point in real time. Since some of the factors that negatively impact coherence (noise and reverberation) also negatively impact speech intelligibility, the coherence trace serves as a useful indicator of system intelligibility as well.

The coherence calculation essentially asks the question “How much of the energy we are seeing in the measurement signal at this frequency was caused by the reference signal?” The answer is a number between 0 and 1, which Smaart displays as a percentage. A value of 100% indicates perfect correlation between the two signals and zero means there is no discernable relationship between them.

In Smaart, the coherence display is plotted in the upper portion of the Magnitude graph, with frequency on the x axis and coherence as a percentage value between 0 and 100 on the y axis. Coherence is always calculated for all transfer function measurements but is only displayed for the topmost trace in the graph – in other words, the trace whose name appears in the upper right corner of the plot. This could be a live measurement or a stored trace, whichever is currently at the top of the z order.

The little arrowhead-shaped widget pointing at the coherence scale on the right side of the Magnitude graph sets the threshold for the coherence blanking function. Coherence blanking removes questionable data from magnitude and phase traces at any frequency for which coherence does not meet or exceed the specified threshold. You can click and drag the widget up and down with your mouse to change the threshold. Alternatively, you can change the numerical value in the *Coh Blanking Threshold (%)* box in *Transfer Function Graph Settings*. Coherence blanking works for all displayed traces, not just the one on the top of the z order, and it works even if the coherence trace is not displayed.

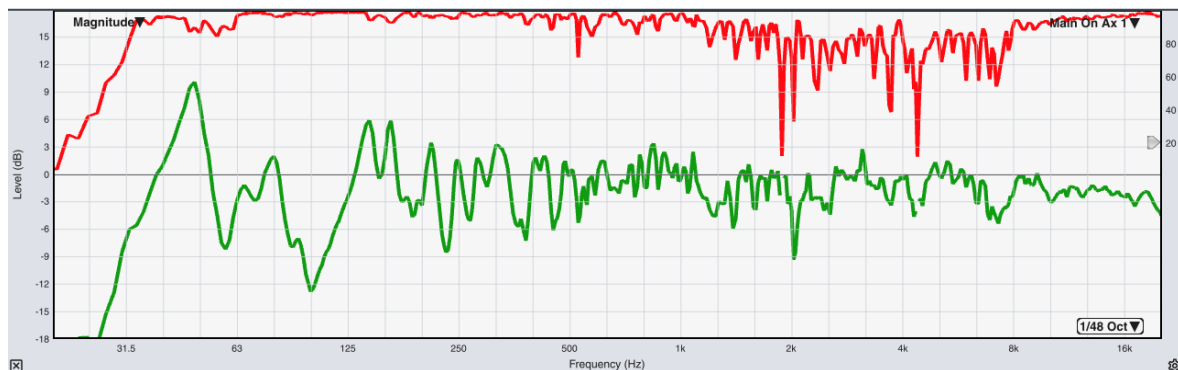

Figure 57 - The red trace across the top of the Magnitude plot is the Coherence trace. Note the vertical scale displayed in the upper right of the plot.

### Causes of Poor Coherence

There are three main factors that are the most common causes of a drop in coherence.

The first is a problem with the measurement or the measurement system. A timing mismatch between the measurement and reference signals will manifest as a drop in coherence if the timing mismatch is a significant

fraction of the measurement time window. Small timing mismatches might not be very visible when using large FFT sizes. When the coherence trace is generated from a Multi-Time Window (MTW) FFT array, as it is in Smart LE, timing mismatches cause coherence to drop first at high frequencies, since the highest frequencies use the shortest time windows, and larger time offsets extend the drop to lower frequencies, creating a characteristic “stair step” pattern that is a tell tale sign of measurement delay not being properly set.

The second cause of low coherence is environmental noise. Any components of the measurement signal that are uncorrelated with the reference signal (background noise, HVAC, construction noise, people talking near your measurement microphone, etc) will have a negative impact on coherence. The solutions are to either measure at a higher level (to increase your advantage over the noise), or find a way to reduce the background noise (by shutting off the HVAC systems or asking the people talking near you microphone to take a break). Using more averaging will probably not increase the overall coherence but it can have a stabilizing effect on the coherence trace.

The third cause of low coherence in a measurement is reverberation. If you have ruled out issues with your measurement system, and coherence does not improve when you measure louder, the likely culprit is reverberation. Reverberation is a non-linear phenomenon but increased proportionally when the excitation sound pressure is increased – measuring louder will not improve the direct-to-reverberant sound ratio. There typically isn't much you can do about it, and it's important to remember that a low-coherence measurement in a reverberant space isn't a *bad measurement*, it's an *accurate measurement of a reverberant space*.

There is an additional, “special case” cause of coherence drops is the presence of distortion products in the measurement signal, for example, if a system under test is non-linear and outputting a distorted signal. In that case, since the distortion products contribute to the overall energy at certain frequencies, we would see a drop in coherence at those frequencies because the signal to noise ratio has been degraded. Although this is unlikely to be observed in typical real-world measurement conditions (as the level of distortion would have to become quite severe and audibly objectionable before it caused a discernible difference in the coherence data), it is often visible under controlled circumstances (test environments that eliminate the three usual causes of low coherence), such as the AES75-2022 standard for measuring loudspeaker maximum linear levels using noise.

---

## LIVE IR

The *Live IR* pane shows the impulse response of the system under test – the time domain representation of its frequency response – continuously recalculated in real time. The *Live IR* graph shows time in milliseconds on the x axis and amplitude / magnitude on the y axis. When the plot is set to *Lin* (Linear), amplitude is shown as a percentage of digital full scale (values between 1 and -1). When the plot type is set to *Log* or *ETC*, magnitude is shown in decibels.

The center point of the time axis is determined by the current measurement delay setting of the transfer function engine being displayed. For stored traces, the center point of the time axis corresponds to the transfer function engine delay setting at the time the data was captured.

The logarithmic (*Log*) view is probably the most familiar to anyone who is accustomed to looking at acoustical impulse responses or IR reverb plugins. The view shows arrival time of the direct sound and the following reverberant decay, plotted on a y axis in decibels.

The linear (*Lin*) view is useful for identifying discrete reflections and can reveal polarity. For example, If you measured two loudspeakers with matched magnitude responses but unmatched polarity, you would note that the prominent peaks in the linear *Live IR* view would point in opposite directions.

The *ETC* view (Energy Time Curve, also sometimes called the Envelope of the impulse response) represents the magnitude of the energy arrival over time by ignoring phase. The textbook description is that the *ETC* data is the real impulse response combined with its Hilbert transform (a copy roated 90° in phase). In more practical terms, *ETC* view tends to fill in the zero crossings seen in the *Log* view of the IR, producing a display that is easier to read.

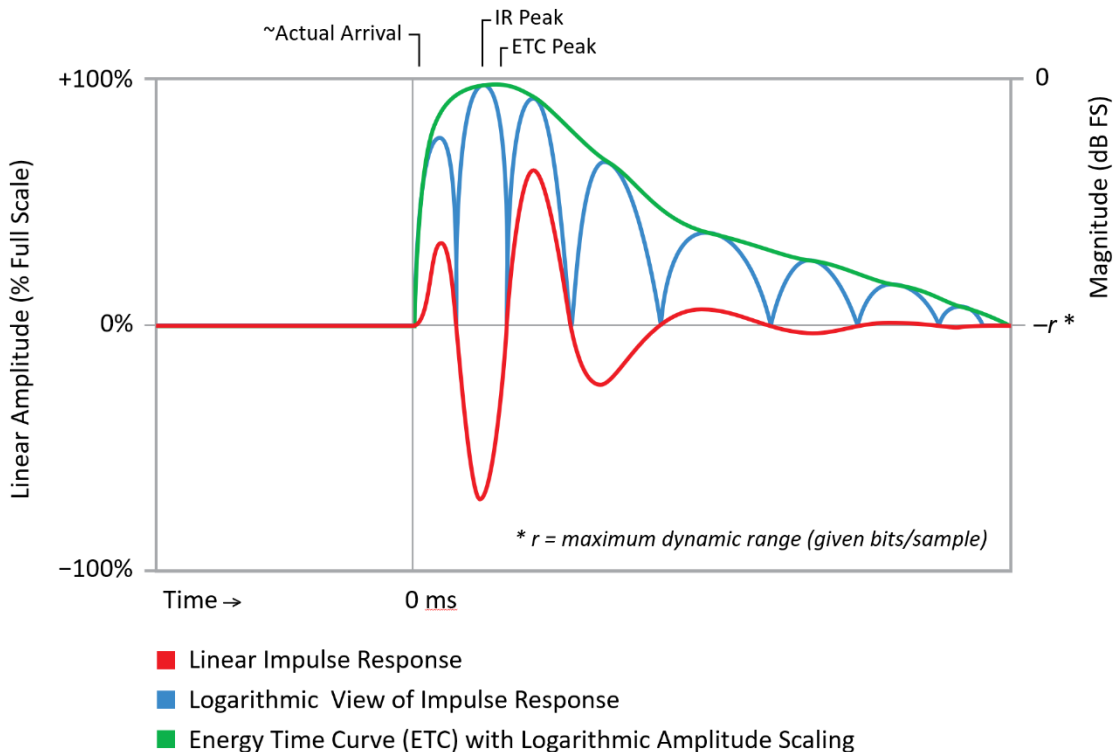

Figure 58 - A comparison of the ETC and the impulse response with linear and logarithmic amplitude scaling

The *Live IR* pane is only shown when at least one frequency domain transfer function plot is visible (*Magnitude* or *Phase*). The pane is hidden when there are no *Magnitude* or *Phase* type plot displayed, and also when it is hidden by deselecting the *Live IR* button in the View flyout. Alternatively, this setting can be toggled by checking or unchecking the *Display Live IR* checkbox in *Options > Graph Settings > Transfer Function*.

The *Live IR* data is calculated independent of the frequency domain transfer function data and so is not affected by the *Averaging Depth* setting in the Control Bar. In Smaart LE, the *Live IR* is calculated using an 8k FFT with 4 FIFO averaging.

---

## MEASUREMENT ISSUES

---

### MEASUREMENT SIGNALS AND SOURCE INDEPENDENCE

Although there exist other mathematical methods by which transfer function data can be derived, the dual-channel method has a unique advantage in that it allows the system response to be measured using any suitably broadband signal material. The measurement therefore does not require any specific or particular test signal to be used – the reference signal simply acts to provide a copy of whatever is being sent into the system, so it can be compared against the measurement signal. This means that a dual-channel measurement can be produced using many varieties of noise, music or other signals. This property is termed “source independence” or “signal independence”. Conceptually speaking, the analyzer does not care what signal is being passed through the system, as long as it is provided a copy.

The obvious qualification is that the signal being used must contain sufficient energy at the frequencies of interest to produce a measurable output from the system at those frequencies. For example, a recording of a flute playing or a soprano singing is not a good choice when measuring subwoofers, because those signals contain very little energy in the subwoofer range. For this reason, pink noise remains a popular choice for real time dual channel transfer function measurement due to its spectral density – you don’t have to wait very long for your measurement to fill in because pink noise consistently contains energy at all frequencies.

---

### WHAT’S IN YOUR MEASUREMENT LOOP?

It’s important to understand that transfer function measurements can only tell us about the system’s response in the portion of the signal path that we choose to measure. For example, if we tapped our reference signal from the mixing console’s output, any processing that happens to the signals before they leave the console would not show up in our measurement, and the console itself would not be considered part of the system under test (SUT) in that configuration. Therefore, we must choose our signal tap points very carefully based on what we are trying to measure, and we must always be aware of what is, and what is not, included in our measurement loop.

---

### DELAY COMPENSATION

Delay compensation is a crucial factor in transfer function measurement. The reference signal for the measurement, regardless of source, is typically connected directly to our audio interface either electronically or digitally, meaning that it travels through a piece of wire to the input of the measurement system, and arrives virtually instantly. The measurement signal, on the other hand, is the output signal of the system under test, so it is subject to delay from filtering, latency, processing, any intentionally added alignment delay, and of course – in the case of acoustical measurements – propagation delay, or the time it takes for the sound wave to travel from the loudspeaker through the air to the measurement microphone, which happens at the speed of sound.

All of this can introduce time offset – potentially tens of milliseconds – between the reference signal and the measurement signal, and since our goal is to compare the two signals, we must compensate for that offset inside Smaart by delaying the reference signal to match the arrival time of the measurement signal. Every transfer function measurement engine in Smaart has a built-in delay line just for that purpose. Delay times for each transfer function engine are displayed in the small numerical field immediately to the right of the engine’s input signal meters.

Smaart includes mechanisms to automatically determine and compensate for delay in the measurement loop.

## Delay Finder

---

The Delay Finder is activated by clicking the *Find* button on the focused transfer function engine in the Control Bar, via *Command > Activate Delay Tracker* or the hotkey [L]. The measurement engine should be running and the signal meters on the measurement engine should show reasonable signal levels for measurement and reference inputs to the engine. The *Delay Finder* window appears and Smart runs the measurement procedure and displays its results when finished.

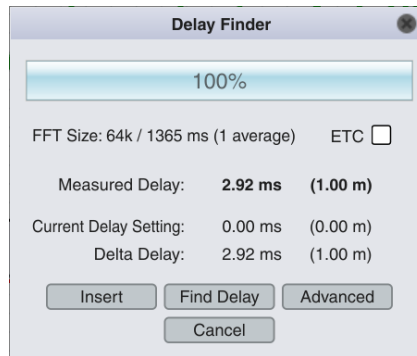

Figure 59 - The Delay Finder dialog

If the measured delay time seems reasonable and you are happy with the results, click the *Insert* button to set the active transfer function engine to the determined delay time and close the dialog. You can also click *Find Delay* to run the measurement again or *Cancel* to close the dialog without changing engine delay time. The *Advanced* button opens the Advanced Delay Finder (see below).

The *ETC* checkbox tells Smart to use the Envelope Time Curve of the impulse response to locate the peak energy arrival, rather than the linear IR itself. This will often result in a slightly different delay time, and one may provide a better answer than the other in a given situation.

You can set the FFT size and number of averages for the basic and advanced delay via the Delay Finder control group in *Options > Measurement Settings > Transfer Function*. The default is a 64K FFT with no averaging, which works out to a time constant of 1365 ms at 48k sampling rate. This is sufficient for finding delay times at distances up to about 450 feet (140 meters) from a source – a good rule of thumb is that the FFT time constant should be least three times greater than the expected delay time. When measuring from extremely long distances or using a sample rate greater than 48k, you may need to increase the FFT size. When working in very noisy surroundings, increasing the number of averages may help as well.

## Delay Tracker

---

Smart's delay tracking feature is designed to keep transfer function measurements aligned in situations where the delay time may change from moment to moment, for example in windy conditions, when the microphone is being moved, or if the PA is swinging. It can also be used as a quicker way to set measurement delay under well behaved measurement conditions when the new delay value is within about 50 milliseconds of the current value.



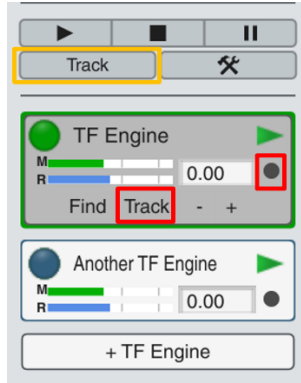

Figure 60 - Delay Tracker controls. The Track button in the focused measurement engine will activate the delay tracker for that engine, as will the circle icon to the right of the delay field. The Track button at the top of the control bar near the measurement controls activates Tracking for all transfer function engines.

The small circle to the right of the delay time field in the measurement engine indicates the status of the *Delay Tracker*. The circle is gray when the tracker is off, turns yellow while it's running (momentary), and red when it's locked on (latched).

Click the tracker circle once to activate it momentarily – the circle will turn yellow, and the tracker will run until it has successfully found the proper measurement delay time. Once it's gotten the same delay value three times in a row, it turns itself off. Double-click the tracker circle to latch it on – the circle will turn red, and it will continue tracking the delay time until you turn it off.

### Advanced Delay Finder

Clicking the *Advanced* button in the basic *Delay Finder* dialog opens the *Advanced Delay Finder* window.

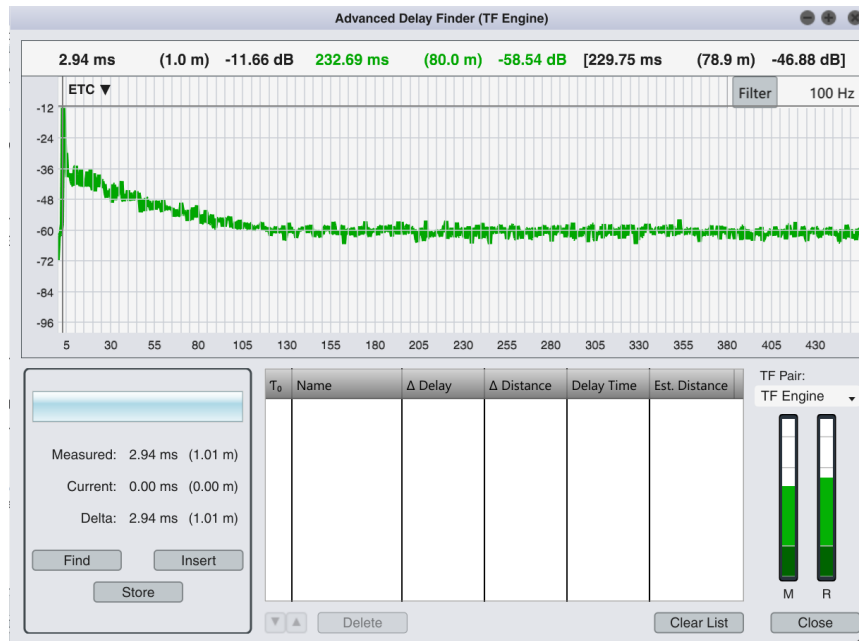

Figure 61 - The Advanced Delay Finder window

The Advanced Delay Finder window is resizable and “modeless,” meaning it can stay open while you work in other Smaart windows. The most obvious feature of the advanced delay finder is that it shows you a graph of the IR measurement instead of just telling you the peak time. The graph type selector in the upper left corner gives you a choice of linear (Lin), Log or ETC plot type. The cursor readout above the plot shows the fixed cursor coordinates on the left, movable cursor coordinates in the center and the delta between the two on the right. You can move the fixed cursor position by holding down the [Ctrl/Cmd] key on your keyboard while clicking on the graph with your mouse and the found delay time will change to match the new position.

Clicking the Filter button in the upper right corner of the graph runs a one-octave bandpass filter on the IR, centered on the frequency specified in the text entry field to the right of the button – this might be the crossover frequency between two systems that you want to align or any other frequency that you would like to isolate.

The control group in the lower left corner of the window presents the same information as the basic Delay Finder window. An IR measurement runs automatically when you open the Advanced Delay Finder window but you can re-run the measurement at any time by clicking the Find button. The Insert button inserts the found delay time as the reference signal delay for the selected transfer function measurement signal pair.

Clicking the Store button adds the found delay time to the table to the right. The table below the graph is a relative delay time calculator. Checking the T0 box next to any entry designates it as the time zero reference and recalculates all of the relative delta ( $\Delta$ ) time and distance

The TF Pair selector to the right of the table enables you to select another transfer function signal pair to analyze. Note that changing this selection automatically re-runs the IR measurement. The level meters show you measurement and reference signal levels for the selected input signal pair. The Close button closes the window.

## AVERAGING – A POWERFUL DATA ANALYSIS TOOL

Averaging is a powerful method for stabilizing measurements, emphasizing trends, and suppressing noise. There are two types of averaging within Smaart: temporal and spatial. Both help highlight what is consistent and suppress the variance in a group of measurements. Spatial averaging highlights trends over a physical area, and temporal averaging helps reveal consistency within a series of measurements taken from the same location.

---

### TEMPORAL AVERAGING

Temporal averaging means averaging a measurement over some period of time. When taking acoustic measurements, there is often a significant amount of noise mixed in with the signal we are trying to measure, which can make each “frame” of measurement differ from the one before it. This causes the readings to fluctuate and jump around on the screen. We would refer to this noisy, hard-to-read trace as an “unstable” measurement.

Smaart is a real-time audio analyzer, so it will keep measuring until we tell it to stop. When these successive frames of measurement are averaged together, the signal components are reinforced, while the random noise

tends to average itself away.<sup>5</sup> This has the effect of stabilizing the measurement, making it smoother and easier to read.

The tradeoff is in responsiveness. Measuring a system response in a highly reverberant environment might require more averaging to stabilize the measurement, but changes we make to the system settings, such as equalization or delay, will take longer to be reflected in the measurement, as new data and old data are averaged together.

One important thing you can do to speed up the process when measuring in a noisy environment is to press the [V] key after making a change to the system. This flushes the averaging buffers and resets the average, causing the measurement to immediately repopulate with current data. This way, you don't have to wait for the older data to fall out of the average before you see the result of your changes.

For electronic measurements, very little averaging is typically required, as noise is not often a significant issue. For acoustic measurements, more averaging is usually required to help stabilize the trace against the contributions of noise and late reverberant energy.

---

## POLAR VS COMPLEX

Since transfer function data is complex in nature (see Complex Data on page 63) there are two mathematical approaches to averaging the magnitude data: *Polar* and *Complex*. Polar averaging calculates decibel magnitudes at each frequency for each incoming measurement frame, and then takes a moving average of the result. Complex averaging keeps two separate running averages of the “real” and “imaginary” parts of the complex signal, and then calculates magnitude and phase from those averages.

Although these two treatments are equally valid from a mathematical standpoint, they can produce slightly different results in various measurement conditions. Polar averaging (sometimes called *RMS Averaging*) tends to be more stable in adverse measurement conditions such as in the presence of wind, HVAC air currents or swinging loudspeakers, and will allow more reverberant energy into the measurement. Complex averaging (sometimes called *Vector Averaging*) has better noise immunity in general and tends to exclude more reverberant energy from the measurement.

In favorable measurement conditions, the difference tends to be rather minimal, however the option can be set independently for each transfer function engine, so it is easy to compare them in real time, to see if one gives you a better answer than the other does in a given situation.

---

## FIFO VS INTEGRATING

There are two different averaging methods used in Smaart's temporal averaging – FIFO and Integrating - that produce different time domain “ballistics”.

A FIFO (First In First Out) average, also known as a Simple Moving Average, always averages together some number of the most recent measurement frames with equal weight. The oldest frame falls out of the measurement when a new frame comes in, hence the name. If you set up an RTA and clap your hands near

---

<sup>5</sup> When two successive frames of measurement are averaged, since the signal is correlated with itself, it sums coherently (+6 dB) while the noise is not, and only increases by 3 dB. Thus each doubling of the number of averages will theoretically increase the signal to noise ratio of the measurement by 3 dB.

the microphone, a FIFO average will cause the level to jump up and remain high until the clap energy falls out of the averaging buffer, then the display will drop back down.

An exponential integrating average, sometimes called “Time Weighting”, is produced by averaging the current measurement frame, with a certain weighting factor, into all the data that’s currently in the averaging buffer. Therefore it could be said that newer data has more weight in the average. Conceptually, you might think of an exponential integrated average as how it takes some time to charge a capacitor, for your furnace to warm up your house, or for a boat to turn after the rudder is changed. The system is always tending towards the new state, but it has some “momentum,” so it takes time to catch up. Another example of this behavior is the natural damping effect of the needle on a VU meter.

Spectrum engines in Smart LE offer the following averaging settings:

- *None* is no averaging, and each measurement frame is displayed in sequence.
- *Fast* mimics the behavior of the *SPL Fast* integration on sound level meters, which has a time constant of 0.125 seconds.
- *Slow* mimics the behavior of the *SPL Slow* integration on sound level meters, which has a time constant of 1 second.
- *Infinite* is infinite averaging, which integrates continuously until the averaging buffer is flushed.

Transfer Function engines in Smart LE offer the following averaging depths:

- *1 = 2 FIFO*
- *2 = 4 FIFO*
- *3 = 8 FIFO*
- *4 = Slow*
- *5 = 1 Sec*
- *6 = 2 Sec*
- *7 = 3 Sec*
- *8 = 5 Sec*
- *9 = 7 Sec*
- *10 = 9 Sec*
- *Inf = Infinite*

---

## SPATIAL AVERAGING

While temporal averaging averages measurements taken from a single location over time, spatial averaging averages measurements taken at different locations. This is useful to help separate system response from localized anomalies occurring at single locations. Spatial averaging answers the question “what is the trend between these positions?”

---

## DB VS POWER AVERAGING

Smaart offers two choices for averages: decibel magnitude (dB) or Power. The distinction lies with what type of data is used to calculate the average. Decibel averaging (sometimes called arithmetic averaging) is a simple average of the decibel magnitude values at each frequency. Power averaging is an average of the squared linear magnitude values at each frequency, with the result converted to decibels.

Conceptually, dB averaging produces a result in which all the contributors are equally weighted – you might say that it creates more of a “consensus” view, whereas power averaging gives more weight to the contributors with higher levels. In the context of evaluating sound system frequency response, power averaging works best if all the measurements being averaged are similar in level. Otherwise, its natural bias towards higher magnitudes means that any measurement that is significantly higher in level than the others will tend to dominate the result. In a dB average, the higher-level measurement won’t affect the overall result more than any other contributor.

Practically speaking, the one advantage of power averaging in this context is that its bias towards the higher magnitudes means that it will de-emphasize the contributions from nulls when averaging data containing comb filters. The nulls of a comb filter are much deeper than the peaks, and so can produce dips in a dB averaged response that might look concerning although they might be largely inaudible to a human listener at any single location.

In Smaart, decibel averaging is the default because we find that it tends to give helpful and useful results in the widest variety of applications, but you can also choose to generate a power average instead – or better yet, generate both and see if one gives you a better answer in a given situation.

### Normalized Power Averaging

---

Normalized power averaging attempts to sidestep the limitations of power averaging in magnitude response measurements by ensuring that all data traces going into the average are approximately equal in overall level before calculating the average. It works by calculating a single-figure decibel average of all frequency data points within a given frequency range for each trace being averaged and then adjusting the overall level of each trace so that their average level within that range is identical.

Transfer function power averages are adjusted so that their average decibel magnitudes for the range of 225 Hz to 8.8 kHz are all 0 dB. When averaging transfer function data, we can assume in advance that we want an averaged magnitude response (as opposed to an average level) and we have a natural reference point (0 dB) to adjust the levels to and so no additional intervention is required. The caveat is that you are also assuming that the system under test has significant energy within the normalization frequency range and if that is not true, e.g., when measuring a subwoofer, you may not get the expected result. In that case, a dB average with coherence weighting may be a better choice.

Normalized RTA power averages work similarly to transfer function power averages except that Smaart cannot assume in this case that you want a normalized average; there isn’t a natural reference point to adjust the levels to, and the normalization range is different. Normalized RTA power averages use 125 Hz to 4 kHz as the normalization range to better accommodate cinema systems and in this case, you must designate one of the traces or measurements being averaged as the reference level.

---

## LIVE VS STATIC

In Smaart, there are two ways to create spatial averages. They can be generated from saved measurement data, for example if you move a microphone around the space to capture a series of measurements, and then average them together to see the trend. Alternatively, spatial averages can be generated in real time by using multiple microphones.

---

## PROTECTING THE AVERAGING BUFFER – IMPROVING DATA

Smaart's measurement calculation pipeline includes a number of methods designed to keep bad or questionable data out of the averaging buffers, off the screen and out of your decision-making processes. These include Magnitude Thresholding, Overload Protection, and Signal Presence Detection.

---

## MAGNITUDE THRESHOLDING

Magnitude thresholding is Smaart's base-level defense against invalid transfer function data. Conceptually, if we did not put anything into the system under test at a given frequency, we should not be getting anything out. Smaart looks at every frequency data point in the reference signal, and for any frequency bins where the level falls below the specified magnitude threshold setting, those bins are omitted when calculating that measurement frame. Bins that fail the thresholding test are simply not updated, and so if a certain bin still contains valid data from a previous measurement frame, Smaart leaves it alone. Frequencies that have never cross the threshold since the measurement began simply remain blank.

This means that, for example, if you were taking a transfer function measurement using music as a test signal, the measurement would continuously only update at those frequencies at which the music has energy at any given time.

---

## OVERLOAD PROTECTION

If Smaart detects three or more consecutive samples with maximum (0 dBFS) amplitude in either the reference or the measurement signal, it assumes that clipping has occurred and will stop updating transfer function measurement data until the overload condition has subsided.

---

## DELAY TRACKER

The Delay Tracker can continuously adjust the measurement delay in realtime in situations where it may change from moment to moment, such as with air movement, wind, or swinging loudspeakers. See Delay Tracker on page 72.

---

## LIVE IR SIGNAL PRESENCE DETECTION

Signal presence detection for the Live IR is similar to magnitude thresholding for the frequency-domain transfer function measurement data. In this case, however, Smaart simply stops processing the Live IR measurement when the reference signal falls below threshold. Smaart will keep checking the input level and resume processing once the reference signal is re-acquired.

## CORRECTION, CALIBRATION, AND COMPARISON

### MICROPHONE CORRECTION FILES

Some measurement mics are sold with files that contain individually measured frequency response data for that specific microphone, which can be loaded in to Smart RT to correct for deviations in the microphone's magnitude response. With mics of reputable quality, these deviations tend to be very minor throughout most of the audible range (tenths of a dB). Although this is important information for laboratory test conditions, these small deviations are dwarfed by the natural variance that occurs in acoustic environments simply by moving the microphone a short distance.

The top pane of the image below shows two measurements taken from the same microphone position with (red) and without (black) the microphone correction file loaded. The bottom pane shows the variation caused by moving the microphone one foot away.

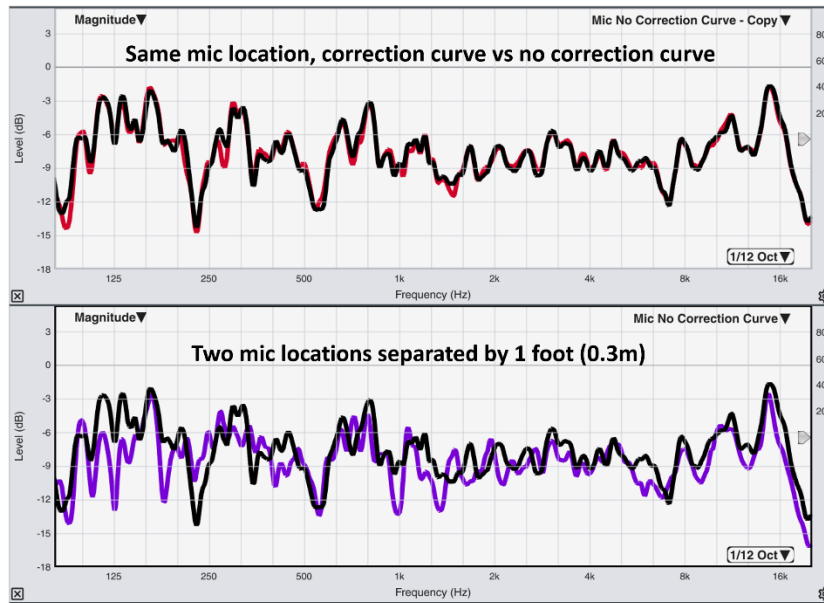

Figure 62 - The effects of a microphone correction file (top) vs the effects of moving the microphone a small distance (bottom)

For this reason, microphone correction files are *not* typically necessary for field measurement work. However, there is a clear benefit to buying a microphone that includes correction data: the confidence that the manufacturer has tested the microphone and it is performing within its design tolerance. In other words: if your mic is of high enough quality to include a correction file, it is probably of high enough quality not to need one.

Smart can import individually measured frequency response data for a microphone in comma- or tab-delimited ASCII text files having one frequency value (in Hz) and one magnitude value (in dB) per line. You can import a new correction curve file by selecting *Import > Mic Correction Curve* from the *File* menu, or by opening the *Mic Correction Curve* dialog from the *Options* menu and clicking *Import*. If the import is successful, the curve should immediately show up in the *Mic Correction Curves* dialog and in the *Mic Correction Curve* dropdown in *IO Config*. If not, the problem is likely a formatting error.

For more information on formatting correction curve files, please refer to the appendix.

---

### SOUND LEVEL CALIBRATION (ONLY NEEDED FOR SPL MEASUREMENT)

All of the measurement data produced by Smaart is produced by analyzing the incoming digital signals. Sound level measurements are unique in that they directly describe the strength of the fluctuations in air pressure occurring at the microphone location. In order to allow produce SPL measurement data, Smaart needs to know what acoustic level at the microphone caused the incoming signal levels. This is accomplished by running the sound level calibration routine.

**Calibration is NOT required for standard Spectrum, Transfer Function or Impulse Response measurements. It is *only* required for measuring SPL.**

To complete the sound level calibration routine, you will need a sound level calibrator, which is a device that produces a known SPL at the diaphragm of the microphone, which Smaart can correlate with the incoming signal level, thus establishing the sensitivity of the entire input signal chain, from microphone to AD convertor.

A sound level calibrator is a precision device that fits snugly over the measurement microphone capsule and generates a known acoustic level. Most calibrators produce levels of 94, 110 or 114 dB SPL, but it is not critical which level your calibrator produces as long as it is known. If your calibrator offers a choice, there is a slight advantage to using the higher level because it increases the signal to noise ratio of the calibration process and makes external and ambient noise less likely to disrupt the process.

When you insert your measurement microphone into the sound level calibrator, do so slowly so as to avoid shocking and potentially damaging the microphone diaphragm. Most calibrators use a rubber seal or gasket of some type to ensure a proper seal. The fit should be snug, without wiggling or play. If you can clearly hear the calibrator's tone once you turn it on, you may not have a solid seal.

Once the calibrator is properly seated and is switched on, open Smaart's *Amplitude Calibration* dialog by one of the following:

- Clicking the *Calibrate* button at the bottom of the *IO Config* dialog
- via *Config > Amplitude Calibration*

The *Amplitude Calibration* dialog has dropdown menus at the top for you to select the device and input you wish to calibrate – ensure the selection is correct before you continue with the process. The *Offset* field displays the calibration offset for that input – the acoustic level that will bring the convertor to 0 dBFS. If the input hasn't yet been calibrated, this number will be 0.0. The level meter on the right shows the signal level for the selected input, with a bit of time averaging applied to smooth out the reading, and should reflect the level of the input signal as caused by the calibrator. Once you have adjusted the input preamp to achieve the desired digital level, click the *Calibrate* button to run the calibration routine.



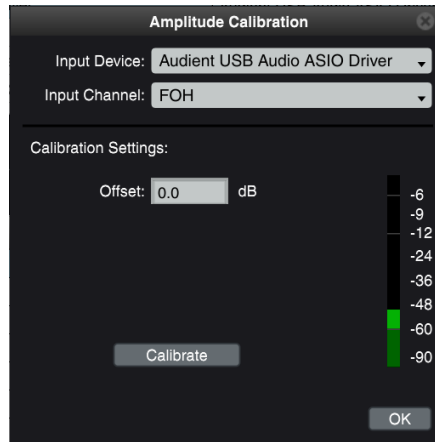

While the calibration process runs, avoid bumping the microphone and calibrator or making unnecessary noise. Once the process completes, it displays the measured digital level in dBFS RMS. Smaart will then ask you what acoustic sound level corresponds to this measured digital level. Enter the level produced by your calibrator into the *Set this value to:* field and press [Enter]. The *Offset Required* value displays the resulting calibration offset, which is the highest sound level that can be accommodated by your measurement setup in its current configuration without overloading your convertor. Click *Okay* to set the offset and close the dialog.

Note that calibration describes the sensitivity of the entire signal chain from microphone to convertor, so if you plug in a different measurement microphone or adjust your interface's preamp gain, you will need to run the calibration procedure again to determine the new offset.

---

## COMPARING MEASUREMENTS

Comparing multiple measurements is one of the most important ways to gain helpful insight from measurement data in Smaart. For example, you can compare multiple transfer function magnitude traces for a look at how the tonal response and level of the system vary over the coverage area, or you might compare phase traces from two different sources to see how well they will align at a given position.

When comparing measurements, it is critical to keep in mind that measurements can only be meaningfully compared if they share a common reference to allow the comparison. For comparing transfer function magnitude measurements, this means preserving the measurement rig's gain structure throughout all measurement acquisition. Since a change to the interface preamp levels for either the measurement or reference signals will cause a corresponding shift in the magnitude trace, this introduces a variable that prevents direct comparison of different measurements. Therefore, you should avoid adjusting the measurement microphone preamp levels during a measurement session if you plan to be able to directly compare the data gathered throughout the session.

Similarly, to use the transfer function phase and Live IR graphs to investigate the relative arrival times of various sources at a given measurement location, the transfer function engine delay time setting must remain constant throughout the process, so the same time reference is used for all measurements. If the measurement delay is reset between measurements, the phase trace and Live IR peak will no longer indicate the relative time or phase offset between the sources.

## 5 – CONFIGURING MEASUREMENT ENGINES

In Smaart, live measurement data is generated by measurement engines. Measurement engines come in two varieties: *Spectrum* measurement engines produce spectrum data and display it on spectrum-type plots (*RTA* and *Spectrograph*), and *Transfer Function* measurement engines produce transfer function data and display it on transfer function-type plots (*Magnitude*, *Phase* and *Live IR*).

Smaart's Control Bar always shows controls and information relevant to the focused plot type. When a spectrum-type plot (*RTA* or *Spectrograph*) has focus, the label *Spectrum* appears at the top of the Control Bar, and spectrum engines and their corresponding controls are displayed.

Likewise, when a transfer function-type plot (*Magnitude*, *Phase* or *Live IR*) has focus, the label *Transfer Function* appears at the top of the Control Bar, and transfer function engines and their corresponding controls are displayed.

Access the *Measurement Configuration* flyout by clicking on the Hammer & Wrench icon in the Control Bar, or via *Config > Measurement Config*, or via the hotkey [Alt/Option] +[G]. This dialog shows all currently configured measurement engines, with *Spectrum* engines at the top and *Transfer Function* engines below.

You can click the minus box (-) next to the Spectrum or Transfer Function heading to collapse the view of all measurements of that type and click the plus (+) to show it again.

The *Device* column shows the input device that is feeding each measurement engine.

In the case of *Spectrum* engines, which are single channel measurements, the input listed in the *Meas. Ch.* column feeds signal to the measurement engine. In the case of *Transfer Function* engines, which are dual channel measurements, the input listed in the *Meas. Ch.* feeds the measurement channel of the measurement engine, and the input in the *Ref. Ch.* column feeds the reference channel of the measurement engine.

At the bottom of the measurement config flyout are a trashcan button to delete the currently selected measurement engine(s), an information button to view configuration details about a selected measurement engine, plus buttons to create new measurement engines.

The *New Spectrum Measurement* and *New TF Measurement* buttons at the bottom of the dialog are used to create new measurement engines of both types, while the *New Spectrum Average* and *New TF Average* buttons create live averaging engines – see *Creating and Configuring Live Averaging Engines* on page 87.

Double-clicking on the measurement's name will make the field editable so you can rename it (be sure to press [Enter] to set the change). Double-clicking on any of the other fields will open the detail view, allowing you to view and adjust configuration parameters for that measurement engine.

### CONTROL BAR MEASUREMENT ENGINE RIGHT-CLICK MENU

Right clicking a measurement engine in the Control Bar opens a context menu that allows you to perform some common operations directly from the top level of the interface. Click *Info* to open the detail view for that engine in the Measurement Configuration flyout.

*Remove from Tab* will remove that engine from the Control Bar, while still leaving it configured for later use. *Remove All Measurements from Tab* does the same for all engines in the Control Bar.

*Duplicate* will create another engine with the same configuration settings.

*Rename* allows you to rename the engine – remember to press [Enter] to set the change.

*Change Color* opens the *Color Selection* dialog to allow you to select a new color for the engine.

You can also drag and drop engines to re-order them in the Control Bar, or drag them out of the Control Bar to remove them from active use.

Engines removed from the Control Bar via either drag and drop, or the *Remove* commands are still configured and available in the Measurement Configuration dialog, from where they can simply be dragged back into the Control Bar for use.

## CREATING AND CONFIGURING SPECTRUM ENGINES

When you selected your input signals (see Initial Configuration – Getting Input Signals on page 15), Smaart automatically created a spectrum measurement engine for each input. You can create additional Spectrum engines by any of the following:

- clicking *New Spectrum Measurement* at the bottom of the Measurement Config flyout
- via *Config > New Spectrum*, via the hotkey [Ctrl/Cmd] + [S]
- by clicking the *+ Spectrum Engine* “ghost engine” that appears in the Control Bar when a spectrum-type plot (*RTA* or *Spectrograph*) has focus.

The *New Spectrum Measurement* dialog prompts you to name the new engine, select a *Device* and a *Channel* for use. Devices and channels, along with their friendly names, will be as specified in the *Input* tab of *IO Config*. Then you can either click *Create +*, which creates the new engine and leaves the dialog open if you’d like to create additional engines, or *Create & Close* which creates the new engine and closes the dialog.

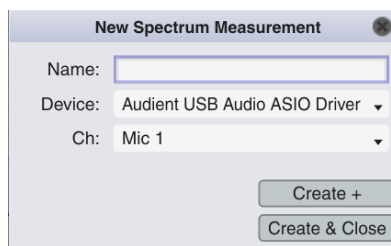

Figure 63 - New Spectrum Measurement dialog

Upon creating the new engine, it will appear in the Control Bar.

Spectrum measurement engine configuration is handled in the engine’s Info detail view, which can be opened by any of the following:

- Right-clicking an engine in the Control Bar and choosing *Info*
- Double-clicking an engine in the Control Bar
- Double-clicking any field other than the engine’s name in the Measurement Config Flyout

- Selecting it in the Measurement Config flyout and clicking the Info button at the bottom of the flyout

[needs screenshot]

The detail view is labeled with the name of the measurement engine at the top. You can view the details of a different engine without closing the flyout by clicking the up and down arrows to the right of the name label, or clicking a different engine in the Control Bar.

The detail view is divided into three fields: *Measurement Settings*, *Display Settings*, and *Input Settings*.

---

## MEASUREMENT SETTINGS

In Smaart LE, the *Measurement Settings* group has four user-adjustable options.

*Name* sets the name of the measurement engine – be sure to press [Enter] to set the name.

*Delay* sets the signal delay time, in milliseconds, for the engine. Usually this setting is left at 0 but there may be circumstances in which you wish to delay the display of the measurement, for example, to more easily compare the ballistics of an *RTA* measurement of a mixing console’s output to that of a microphone placed some distance from a loudspeaker. Note that this is a special case setting and should not be confused with the measurement delay for *Transfer Function* measurement engines.

*FFT* sets the FFT size used by the measurement engine. By default, the *Use Global* checkbox is checked, which means the engine will use the global FFT size setting in *Options > Measurement Settings > Spectrum*. Un-checking *Use Global* will enable the *FFT* dropdown and allow you to select an FFT size specific to this engine. Available sizes are power-of-two FFTs from 128 to 32k samples.

*Averaging* sets the temporal averaging used by the measurement engine. By default, the *Use Global* checkbox is checked, which means the engine will use the global Averaging setting displayed in the Control Bar atop the Spectrum engine controls. Un-checking *Use Global* will enable the *Averaging* dropdown and allow you to select an Averaging setting specific to this engine. Available options are *None*, *Fast*, *Slow* and *Infinite*.

---

## DISPLAY SETTINGS

In Smaart LE, the *Display Settings* group has two user-adjustable options.

Clicking on the *Color* swatch will open the *Color Selection* dialog and allow you to select a color for the measurement engine. See Trace Color and Thickness on page 36.

*Plot* sets which plot the engine’s trace will appear on, in situations when more than one of the same plot type is available, for example, the *RTA/RTA* view. When only a single plot of a given type is available, this setting is ignored. See Moving Traces on page 35.

---

## INPUT SETTINGS

The *Input Settings* group allows you to choose the signal that feeds the measurement engine. The *Device* dropdown lists all input devices that are selected for use in the *Input* tab of *IO Config*, and the *Channel* dropdown will allow you to choose an input channel from those you have enabled for use. These dropdowns will use the *Friendly Names* for the device and the channel if they have been specified in *IO Config*.

## CREATING AND CONFIGURING TRANSFER FUNCTION ENGINES

Transfer Function engines can be created by any of the following:

- clicking *New TF Measurement* at the bottom of the Measurement Config flyout
- via *Config > New TF*
- via the hotkey [Ctrl/Cmd] + [T]
- by clicking the *+ TF Engine* “ghost engine” that appears in the Control Bar when a Transfer Function-type plot (*Magnitude*, *Phase* or *Live IR*) has focus.

The *New TF Measurement* dialog prompts you to name the new engine, select a *Device*, and specify which inputs you want to use for the Measurement and Reference channels of the engine. Then you can either click *Create +*, which creates the new engine and leaves the dialog open if you’d like to create additional engines, or *Create & Close* which creates the new engine and closes the dialog.

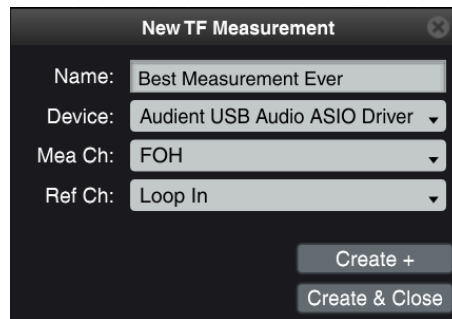

Figure 64 - New TF Measurement dialog

Upon creating the new engine, it will appear in the Control Bar.

Transfer Function measurement engine configuration is handled in the engine’s Info detail view, which can be opened by any of the following:

- Right-clicking an engine in the Control Bar and choosing *Info*
- Double-clicking an engine in the Control Bar
- Double-clicking any field other than the engine’s name in the Measurement Config flyout
- Selecting it in the Measurement Config flyout and clicking the Info button at the bottom of the flyout

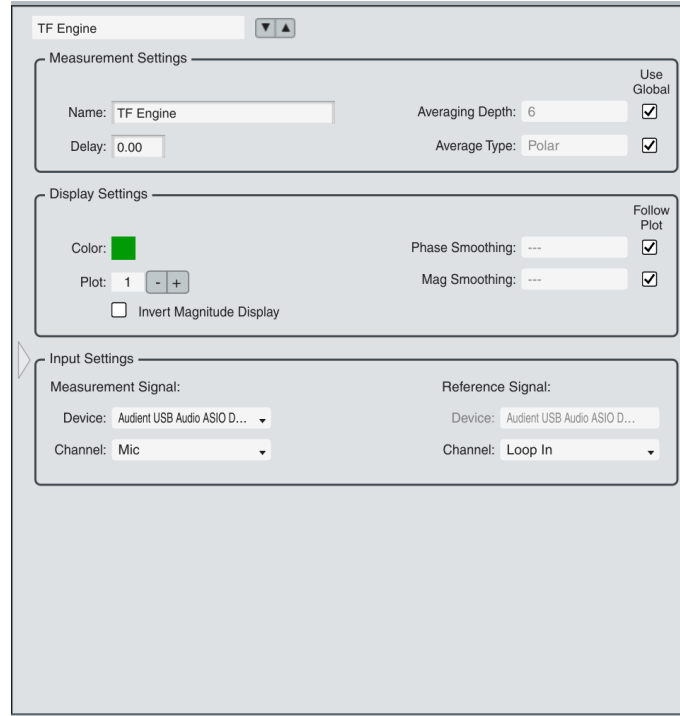

Figure 65 - Transfer Function engine configuration flyout

The detail view is labeled with the name of the measurement engine at the top. You can view the details of a different engine without closing the flyout by clicking the up and down arrows to the right of the name label, or clicking a different engine in the Control Bar.

The detail view is divided into three fields: *Measurement Settings*, *Display Settings*, and *Input Settings*.

---

## MEASUREMENT SETTINGS

In *Smaart LE*, the *Measurement Settings* group has four user-adjustable options.

*Name* sets the name of the measurement engine – be sure to press [Enter] to set the name.

*Delay* sets the amount of signal delay (in milliseconds) necessary to align the reference and measurement signals. Positive values delay the reference signal (the most common case). Entering a negative number delays the measurement signal.

*Averaging* sets the temporal averaging depth used by the measurement engine. By default, the *Use Global* checkbox is checked, which means the engine will use the global Averaging setting displayed in the Control Bar atop the Transfer Function engine controls. Un-checking *Use Global* will enable the *Averaging* dropdown and allow you to select an Averaging setting specific to this engine. Available options are 1 thru 10 plus *Infinite*.

The numbered values correspond as follows:

- 1 = 2 FIFO
- 2 = 4 FIFO
- 3 = 8 FIFO

- 4 = *Slow*
- 5 = *1 Sec*
- 6 = *2 Sec*
- 7 = *3 Sec*
- 8 = *5 Sec*
- 9 = *7 Sec*
- 10 = *9 Sec*

*Average Type* sets the mathematical averaging type used by the measurement engine to either *Polar* or *Complex* averaging. By default, all transfer function engines will use the global *Mag Averaging Type* average type setting in *Options > Measurement Settings > Transfer Function*. Unchecking the “Use Global” checkbox will enable the dropdown allowing you to select which averaging type should be used for this engine.

For information about the difference between the two averaging methods, and why you might choose one or the other, see *Polar Vs Complex* on page 75.

---

## DISPLAY SETTINGS

Clicking the *Color* swatch opens the *Color Picker* which allows you to choose a display color for the measurement engine. See *Trace Color and Thickness* on page 36.

*Plot* sets which plot the engine’s trace will appear on, in situations when more than one of the same plot type is available, for example, the *Magnitude/Magnitude* view. When only a single plot of a given type is available, this setting is ignored. See *Moving Traces* on page 35.

*Invert Magnitude Display* will plot the engine’s magnitude response upside down. This can be helpful when setting loudspeaker equalization, as it allows a cut to be displayed as a boost, making it easier to see whether the filter response is appropriately complementary to the loudspeaker response being equalized.

The *Phase Smoothing* and *Mag Smoothing* fields allow a measurement engine to override the in-plot smoothing settings. Un-checking the *Use Global* checkbox will enable the dropdown menu.

---

## INPUT SETTINGS

The two sets of *Device* and *Channel* dropdowns allow you to select input signals to the engine’s Measurement and Reference inputs. If the *Allow Multi-Device TF* option is enabled in *Options > Settings > Advanced*, you will be able to select Measurement and Reference signals from different devices. Caution should be observed when taking a transfer function between different devices, as this cause result in clock drift in the measurement, resulting in unreliable phase / impulse response data.

## CREATING AND CONFIGURING LIVE AVERAGING ENGINES

In addition to generating averages from stored measurement data, Smaart can also generate averages from the output of multiple measurement engines in real time. To create a live average engine, click either *New Spectrum Average* or *New TF Average* at the bottom of the Measurement Configuration flyout.

## LIVE SPECTRUM AVERAGE

The *New Spectrum Average* button opens the *New Measurement Average* dialog.

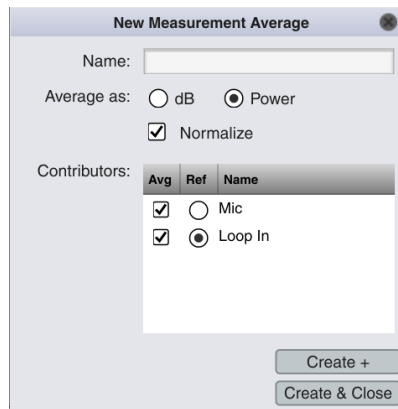

Figure 66 - New Measurement Average dialog for Spectrum engines

You are prompted to give the new engine a name, and choose either *dB* or *Power* averaging. Select the checkboxes for the engines you want to contribute to the live average. Enabling *Normalize* will ensure that the outputs from all contributing spectrum engines are adjusted to be approximately equal level before being averaged with each other – you can indicate which engine should be used as the normalization reference by selecting its *Ref* radio button. (For more on dB vs Power averaging and normalization, see dB vs Power Averaging on page 77.) Clicking either *Create +* or *Create & Close* will create the live average engine.

Live Transfer Function average engines are created in much the same way – click *New TF Average* and give it a name, choose the averaging type and whether you’d like it to be *Coherence Weighted*, then select the transfer function engines you wish to contribute to the average.

Once live average engines are created, they behave much like any other measurement engine, with hide/show and run/stop controls in the Control Bar. Any measurement engines that are members of live average engines are always contributing their data to the average, regardless of whether they are shown or hidden, as long as they are running. Stopping a measurement engine will remove its contribution from the live average engine.

## ADDING AND REMOVING ENGINES IN THE WORKSPACE

The Measurement Configuration flyout lists all configured Spectrum and Transfer Function measurement engines. Measurement engines “live” in the Measurement Configuration flyout and can be dragged into the Control Bar when you want to use them, and then removed when you’re done with them.

To add a measurement engine to the workspace, simply drag and drop it from the Measurement Configuration flyout into the Control Bar. To remove it, you can either simply drag it out of the Control Bar (it will disappear once you release your mouse button), right-click the engine and choose *Remove From Tab*, or clear them all at once by right-clicking any engine and choosing *Remove All Measurements from Tab*.

## MEASUREMENT ENGINE CONTROLS

All measurement engines in Smaart have a triangle-shaped “Run” icon that looks very much like a “Play” icon on a multimedia device. Clicking the Run icon will turn the icon green and start the measurement engine



running. This also activates the engine's signal level metering, which transitions from dark green to light green at signal levels of -60 dBFS, light green to yellow at -12 dBFS, and yellow to red at -6 dBFS. Click the Run button again to turn it grey and stop the measurement engine.

All measurement engines have a colored circle on the left side of the engine area which corresponds to the color of the data trace that engine will produce in the graphs. Clicking on the colored circle will hide its data from the graphing area, as indicated by the "X" that appears over the colored circle to indicate the hidden state. Clicking again removes the "X" and unhides the live measurement data.

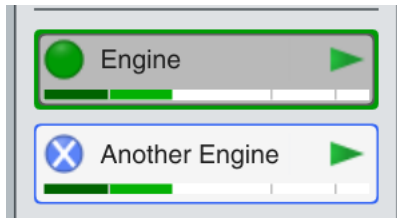

Figure 67 - Two spectrum engines, one shown and one hidden

When you stop an engine, its output is automatically hidden, but you can click the colored circle to show the data that is still in the measurement's averaging buffer. The Pause All button at the top of the Control Bar effectively accomplishes both operations with a single click: stops the engines from running, but keeps their data displayed on the graph.

At the top of the Control Bar are controls to Run All, Stop All and Pause all measurements. Run All will run all measurement engines. Stop All will stop them and hide them, while Pause All will stop them and keep their output visible on the graphs.

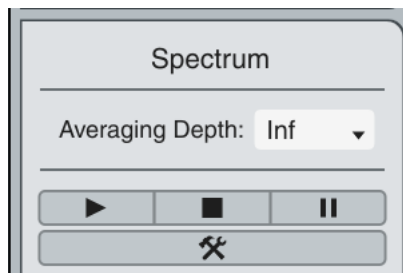

Figure 68 - Spectrum Measurement controls in the Control Bar

Transfer Function measurement engines have additional controls: instead of a single input level meter, there are a pair of input meters labeled *M* and *R* for the measurement and reference signals. A delay time field shows the measurement engine delay setting, in milliseconds. (See Delay Compensation on page 71). The small circle to the right of the delay time field indicates the status of the *Delay Tracker*. The circle is gray when the tracker is off, turns yellow while it's running (momentary), and red when it's locked on (latched).

Click the tracker circle once to activate it momentarily – the circle will turn yellow, and the tracker will run until it has successfully found the proper measurement delay time. Once it's gotten the same delay value three times in a row, it turns itself off. Double-click the tracker circle to latch it on – the circle will turn red, and it will continue tracking the delay time until you turn it off.

When you click on a measurement engine to give it focus, the engine enlarges slightly to make room for another row of controls that appears.

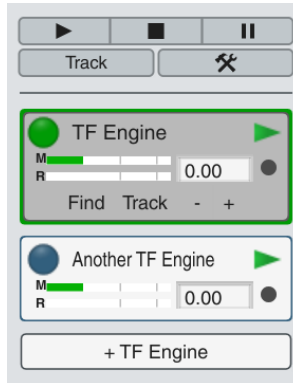

Figure 69 - Transfer Function engine controls. The first engine has focus and its expanded controls for measurement delay can be seen

*Find* opens the Delay Finder dialog and begins the process of finding the measurement delay. See Delay Compensation on page 71. *Track* turns on the Delay Tracker – one click for momentary operation (yellow indicator), and two clicks for latched (red circle). When the Tracker is latched on, click *Track* to turn it off.

The + and – buttons adjust the measurement delay value up or down by the increment specified in the +/- *Increment* field in the *Options > Measurement Settings > Transfer Function* dialog, where it can be specified in either samples or milliseconds.

## 6 – MAKING MEASUREMENTS

Up to this point, we have learned about how to navigate and control Smaart and reviewed some fundamental measurement concepts. Now we will apply that knowledge in the context of a practical measurement workflow. We discuss here a typical generalized measurement workflow – the reader is encouraged to consider how they would adapt the process to meet their specific needs in a given situation.

### WORKING FROM DEFAULTS

Given how much of this user guide is devoted to describing the various settings and parameters that may be adjusted by the user, it should come as no surprise that overlooking or forgetting that some settings have been adjusted can create unexpected measurement results and unintended behavior. For this reason, the user is strongly advised to begin a new measurement setting by restoring Smaart to defaults via *Config > Manage Configurations > Restore Defaults*.

(Unlike in previous version of Smaart, restoring Smaart v9 to defaults happens in just a few seconds and doesn't necessitate a program restart, so it's a painless procedure.)

Once the program has reset, we are greeted with a message explaining that no measurements are configured, and we should begin the process by selecting input sources. Clicking *OK* brings us to the *Input* tab of the *IO Config* dialog.

### INPUT AND OUTPUT SELECTION AND NAMING

For most measurement applications, all inputs will be coming from a single input device – selecting one will populate the bottom table in *IO Config* with a list of all the device's inputs, and will select up to the first 8 for use by default. From here, we want to select and name the inputs we will use during our measurement session and deselect the rest.

We can quickly Select / Deselect all a device's inputs by clicking the word *Use* in the table's column header. Selecting only the inputs needed for our session ensures that as we then configure our measurement engines, we will only be presented with signals we're using as options. Each input in use gets a descriptive name, so we can recognize it everywhere it shows up in the program – and by default, this name will be adopted by the spectrum engines that are automatically created for each input as well.

When setting up output devices, it is a good idea to assign a Friendly Name to each output describing where that signal is going – “To Loop,” “To DSP,” and so forth, makes output selection streamlined and minimizes the chance of confusion or misconfiguration.

### MEASUREMENT SETUP

Before we begin configuring Smaart for our purposes, we must consider what we wish to measure and translate that into an effective measurement configuration. Where should we pull signal tap points from? How many signals do we need to work with simultaneously?

The use of friendly names coupled with the de-selecting of unused inputs during the input configuration process ensures that when we start creating the desired transfer function engines, Smaart only offers us a choice of clearly labeled inputs that have been selected for use, which speeds the configuration process and decreases the chance of making a mistake.

---

## SIGNAL TAP POINTS

Some consideration of what signals we wish to observe, or in other words, where in the sound system's signal flow we want to tap the signal from, is in order. The mixing console output is helpful as the reference channel in a transfer function analyzing the sound system response, but also to observe directly via spectrum measurement. In addition, feeding a spectrum engine from the mixing console's cue / solo output affords a close look at signals of interest.

For a standard sound system alignment workflow, we can remove from the equation many complicating variables having to do with the mixing console by simply injecting our generator signal directly into an input of the DSP. If the generator is then also looped back locally at the IO device (from an output directly back to an input), this configuration, combined with a measurement microphone to capture the system's output, allows transfer function analysis of the entire sound system transmission chain – from DSP inputs, through amplifiers and loudspeakers to the listening area. The entire system is in the measurement loop, and we will gain an understanding of what effect the sound system will have on the signals leaving the mixing console.

## GAIN STRUCTURE AND SIGNALS CHECK

Our measurement session begins by setting the gain structure of the measurement rig and conducting a signals check. Turning on the signal generator to a reasonable level, say, -12 dBFS and routing it through the system under test while observing Smaart's input meters will allow us to make sure that all the selected inputs are properly receiving signal. Gain can be adjusted on each to bring the inputs into the analyzer at a healthy level (-12 dB is a good target, right where the meters transition from green to yellow).

Microphone preamps can be set by raising the system level to the desired measurement level (not too loud, perhaps 15 dB SPL above the noise floor is all that's required) and then adjusting the microphone preamp to bring the signal up to -12 dB FS or so.

We can view all input signals at once by clicking the Run All button at the top of the Control Bar to start all spectrum engines running and then pressing the [0] key to launch multi-spectrum view.

---

## MICROPHONE CORRECTION CURVES

Some measurement microphones include files with individually-measured frequency response data that can be loaded into Smaart to correct for deviations in the microphone's magnitude response. With mics of reputable quality, these deviations tend to be very minor throughout most of the audible range (tenths of a dB). Although this is important information for laboratory test conditions, these small deviations are dwarfed by the natural variance that occurs when measuring in acoustic spaces simply by moving the mic a short distance.

The top of the image below shows a measurement taken from the same microphone position with (red) and without (black) a correction file in use, and the bottom pane shows the variance caused by moving the microphone a foot away.

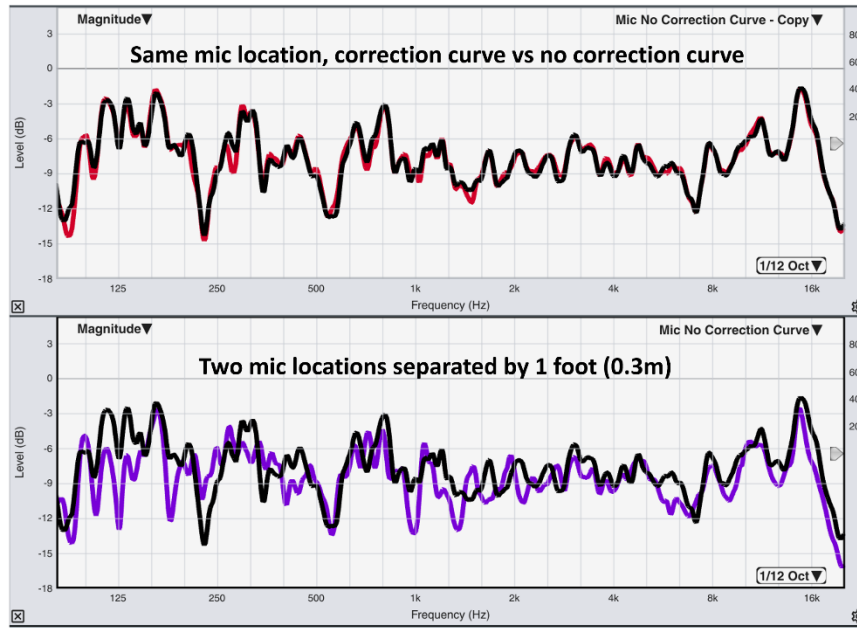

Figure 70 - The effects of a microphone correction file (top) vs the effects of moving the microphone a small distance (bottom)

For this reason, mic correction files (not to be confused with “calibration”) are not necessary for typical field measurement work. However, there is a benefit to buying a microphone that includes individual correction data: the confidence that the manufacturer has tested the microphone and it is performing within its design tolerances. In other words: if your mic is of high enough quality to come with a correction file, it is probably of high enough quality not to need it.

Since a microphone correction file adds offsets to the magnitude data early in the measurement pipeline, it cannot be removed from the measurement after the fact, and users often accidentally leave a microphone correction file assigned to an input while plugging in a different microphone, or taking an electronic measurement, producing unintended results. Thus, in a typical situation, there is little benefit from using microphone correction files in Smaart, and also a potential penalty for using one “accidentally.”

---

## MULTIPLE MICROPHONE WORKFLOWS

Multiple microphones allow the acquisition of system response data from multiple listening locations at the same time. Since the alternative would be to move a single microphone around the space to the desired measurement locations, we are faced with the tradeoff of lower cost but higher acquisition time (single microphone being moved around), or higher cost (more microphones and a larger I/O device) vs faster acquisition.

When multiple measurement microphones are to be used, we begin with a microphone verification process, which involves placing all the microphones in close proximity and ensuring they all provide the same answer. Preamps can be adjusted to compensate for different microphone sensitivity until the traces from all microphones overlay.

## CHANGING SETTINGS

Smaart’s defaults have been carefully chosen over many years of development to allow you to achieve actionable data without first having to make an extensive visit to the program’s settings, and without deep knowledge of measurement mathematics. As such, it can safely be assumed that Smaart will get the job done in most situations running from the default settings, and can be adjusted as required by more specialized use cases.

## DATA ACQUISITION

Once the measurement rig has been configured and verified, data acquisition can proceed quickly. We can use the *Fade In* and *Stop Gen After Capture* signal generator settings to minimize disturbance to other parties working in the area and minimize the amount of time noise is being played through the system.

It takes a handful of seconds to switch on the generator, set measurement delay using either *Find or Track*, flush the average ([V]), and capture the data, naming it after the noise stops. The data can then be analyzed, considered, any necessary system parameters adjusted, the mic relocated to a desired location, and the process repeated.

Once the drive level of the system has been increased until the coherence trace stops improving, there is no further benefit to be gained by measuring louder. Thus, a system can be quickly and effectively measured using very short periods of noise at moderate levels, minimizing disturbance.

## DATA LABELING AND ORGANIZATION

Care should be taken to label stored measurement data in a way that will be useful if the data is revealed later. Simply relying upon the automatically suggested, numerically incrementing names will offer no context later. It is helpful to use descriptive names that include what part of the sound system is being measured and where the microphone was located. Numbering the data into discrete steps (for example: all Mic Verify traces are step 0, all “Pre EQ” traces are step 1, all Post EQ traces are step 2, and so forth) streamlines the data review process and conveniently allows the operating system to sort the data into a helpful order if it is transferred to another computer.

---

## COLORING AVERAGES

When working with averaged data – either created by a live averaging engine, or generated from multiple stored traces – it is helpful to set the trace color to either white (when using the dark color scheme) or black (when using the light color scheme). Since Smaart will never randomly assign white or black to a captured trace, that color coding is a helpful visual shorthand that the data in question is an average.

## SENDING DATA TO A COLLEAGUE

After a measurement session, you may wish to share the captured data with a colleague or client. All stored measurement data is housed in your computer’s Documents directly, inside the Smaart LE\Data folder, and further divided by data type (Spectrum or Transfer Function). Alternatively, you can right-click a saved trace in the Data Library and choose *Open File Location* to open your operating system’s file browser to that trace’s location on your hard drive. From here, it’s simple to copy the desired measurement data, or an entire folder,

to send to friends. Stored traces are small files (KB, not MB) and so can be easily transferred or stored without bandwidth or data capacity concerns.

### **A GHOST IN THE MACHINE**

If Smaart begins to exhibit unexpected behavior and you can't seem to track down the culprit, you can quickly flush out any settings or configuration trouble that may be causing the issue by restoring the program to defaults (*Config > Manage Configurations > Restore Defaults*). This will reset the program configuration but preserve all captured measurement data, so your work will not be lost.

## 7 – MEASUREMENT EXAMPLES

The following examples are designed to help you get acquainted with measurement procedure and workflow. The reader is strongly encouraged to work through the measurements themselves, with their own software and measurement rig.

### SETTING EQ FOR A LOUDSPEAKER

In this procedure, we will measure a loudspeaker's response from a few locations within its coverage area, create a spatial average of the data, and then set some equalization filters to address the response deviations, resulting in a more natural tonality for the loudspeaker. We will also use the Invert Magnitude function to confirm that our filter choices represent a good complementary response for the loudspeaker's acoustic response.

For illustrative purposes, we will start with Smaart running from defaults. We begin by choosing our input signals in *IO Config* and giving them friendly names – *Mic* and *Loop In* – as well as selecting outputs to drive the loopback and the system under test, which for this example consists of a processor and a loudspeaker. Our measurement mic is placed in the center area of the loudspeaker's coverage.

To keep our acquired data organized, we can click the hamburger (three-line) menu at the top of the Data Bar and choose *New Session Folder*, giving it a detailed name. This folder will hold all the measurement data captured during our session.

Selecting the inputs in *IO Config* has created a spectrum engine for each using the friendly names we specified. We can click the Run All button in the Control Bar to start both spectrum engines running, then press the [O] key to open Multi-Spectrum view. We set the generator to a reasonable level, and run it using the [G] hotkey, adjusting the gains on the audio interface until both signals read at similar, healthy levels – around where the meters transition from green to yellow, which is -12 dBFS.

Viewing both signals' spectrums assures us that our patching is correct and our signal acquisition is good. If we want to quickly view either input signal in more detail, we can click to focus that plot and then press the [Enter] key to blow it up to the full window size.



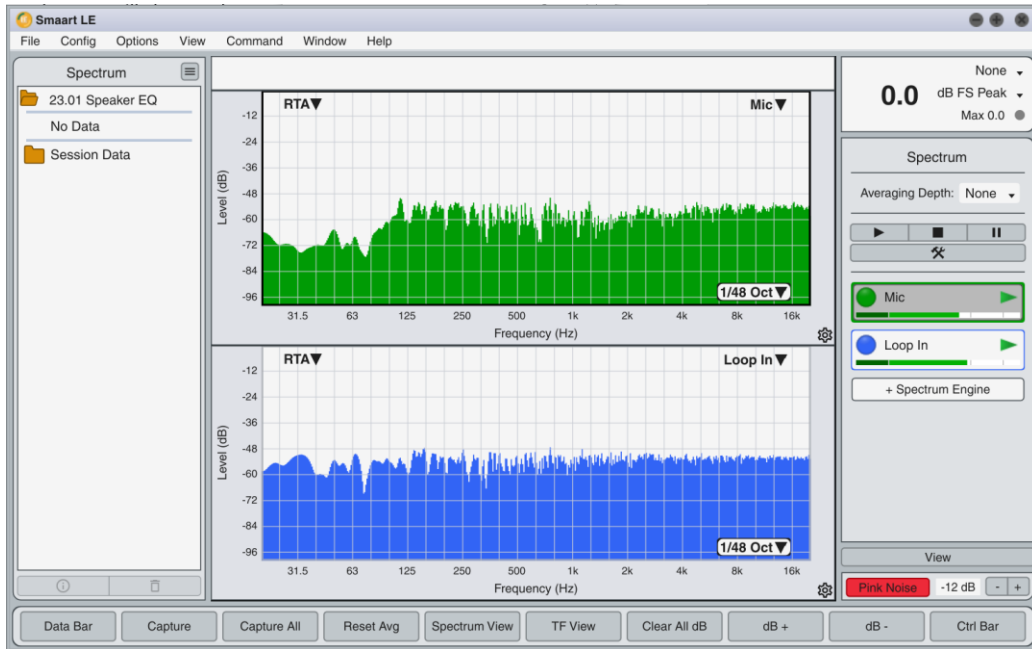

Figure 71 - Viewing both input signals in Multi-Spectrum view to confirm good acquisition before beginning transfer function measurement work.

Now, we will move to *Transfer Function* view by opening the *View* flying and clicking the *T* button. We need to create a Transfer Function engine using these two inputs, which we can do by clicking the *+ TF Engine* ghost engine button in the Control Bar to open the *New TF Measurement* dialog, naming the engine, and selecting the Mic as the measurement channel and the Loop In as the reference channel. Clicking *Create & Close* creates the engine and we are ready to work.

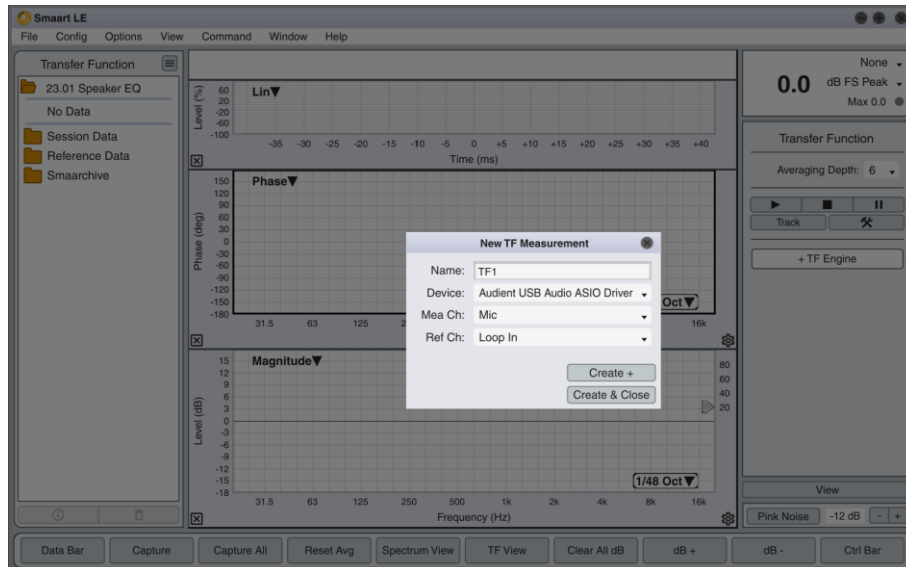

Figure 72 - Creating a new TF engine

We click the *Run* button to start the transfer function measurement engine running and observe healthy signal levels on both of the engine's level meters. As measurement data begins to populate in the graphing area, we see the telltale signs of an incorrect measurement delay.

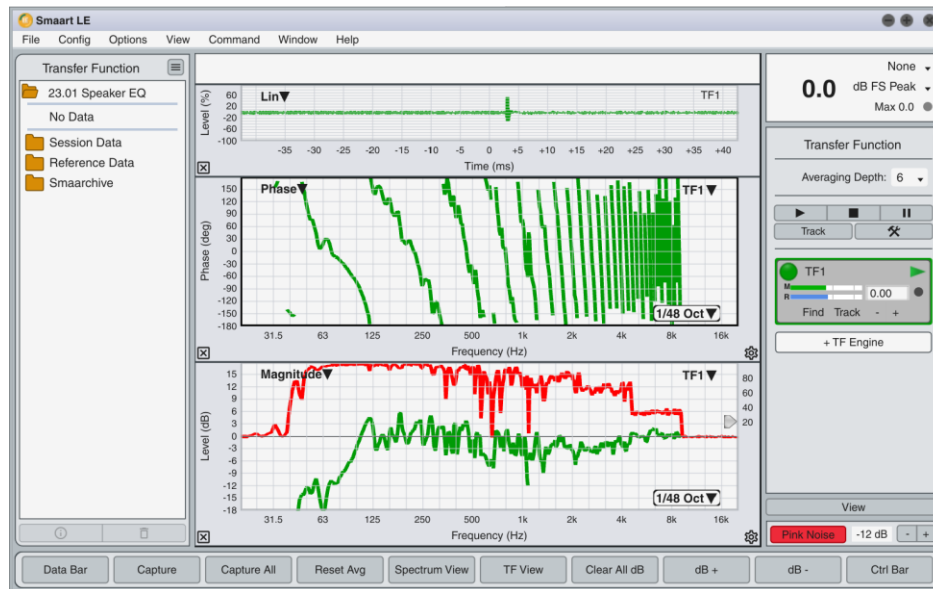

Figure 73 - Transfer Function data with improperly set measurement delay

There are four such indications: 1) Peak in the Live IR is offset from center, 2) steep wrapping in the *Phase* trace, 3) stair stepping down in the coherence trace towards high frequencies, and 4) a value of *0.00* in the measurement engine delay field.

To properly set the measurement delay, let's click the *Find* button and let the Delay Finder produce a suggested measurement delay value.

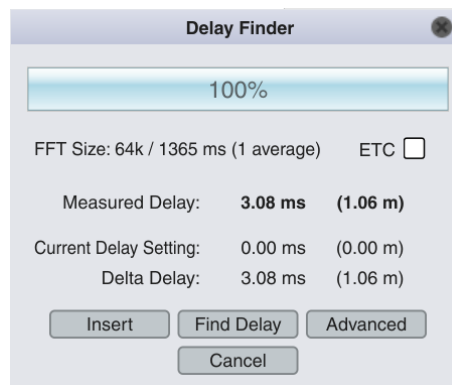

Figure 74 - Delay Finder suggests a measurement delay value of 3.08 ms.

Since the microphone is a few feet from the loudspeaker, this suggested delay time makes sense, so we can click *Insert* to accept it. Now the data looks quite healthy.

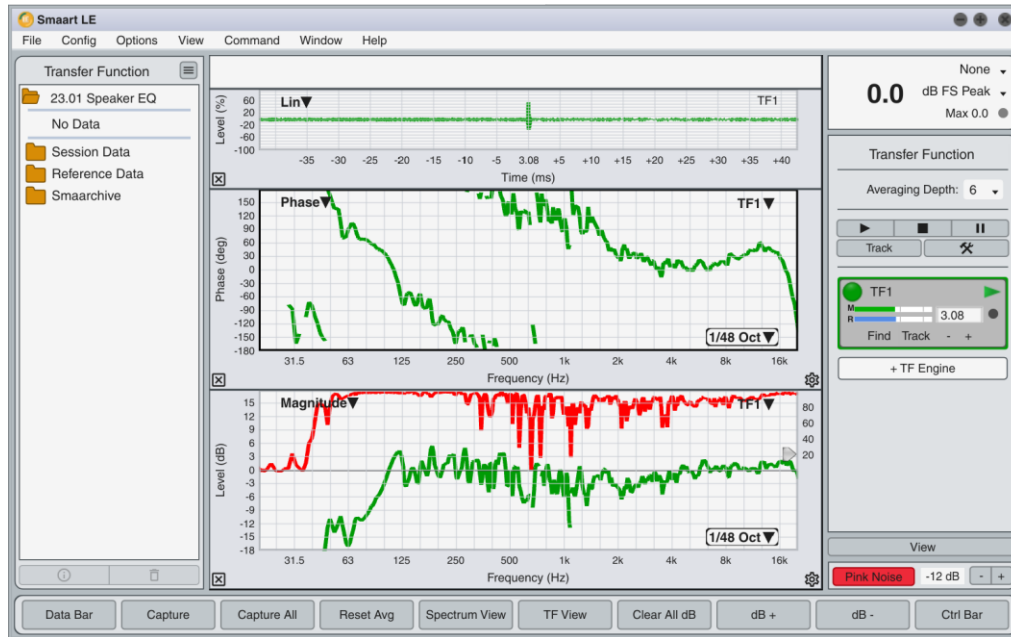

Figure 75 - Transfer Function measurement of a loudspeaker with properly set measurement delay time.

We will capture this trace using [Spacebar] and give it the name Pre EQ 1, then move our mic to another location within the central coverage area of this loudspeaker. Once we move the mic, we will again see indicators that the measurement delay needs to be reset. Since we have only moved a short distance and are working in favorable measurement conditions, we can use the Delay Tracker to quickly adjust to the proper measurement delay value and then turn itself off by clicking the *Track* button in the measurement engine.

Once the new measurement delay value is set, a quick tap of the [V] key will flush the averaging buffer and populate our measurement with fresh data. Let's save this as Pre EQ 2, and then repeat the process to take a third measurement from another nearby position.

Now that we have three saved measurements from within the coverage area of the loudspeaker, we can click the colored circle in the transfer function engine to hide the trace while we work with the saved data. Since we intend to EQ for the general common trend, we set our smoothing to 1/6 Octave using the smoothing control in the lower right corner of the plot.

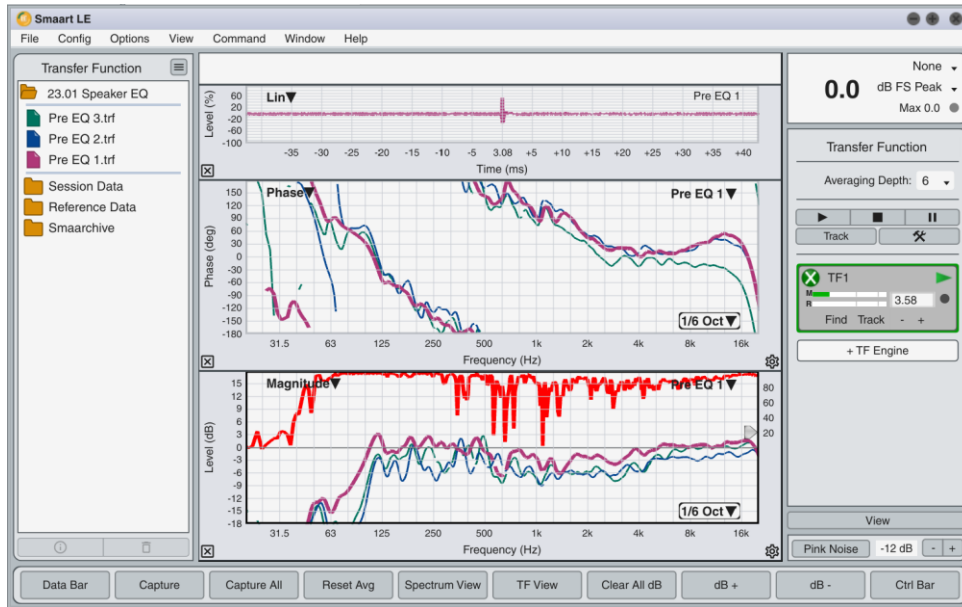

Figure 76 - Three measurements from within the coverage area with 1/6 Octave smoothing

In the example, we can see that the pink trace was probably taken closest to the loudspeaker since it's the highest broadband magnitude. We can confirm this by tapping the [Z] key to toggle through the z-order for the three displayed traces, and noting the measurement delay times shown for each in the center of the Live IR pane, with the pink trace showing the lowest delay time (closest mic position), and having the highest coherence (best direct:reverberant ratio).

We want to create a spatial average of these three traces by multi-selecting them (click the first measurement in the data bar, then hold [Shift] and click the last) then right-clicking and choosing *Average* from the Data Bar right click menu.

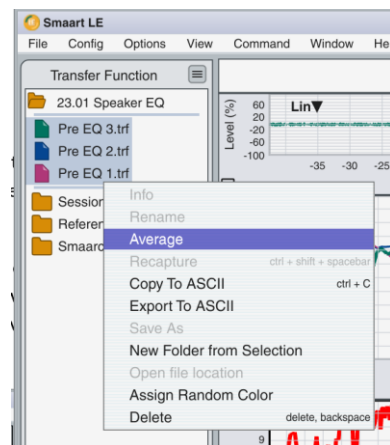

Figure 77 - Creating an average from the three selected traces

In the Trace Average dialog, we set a descriptive name of *Pre EQ Average* and assign the color as Black, then click OK. The resulting spatial average is shown as a black trace, and appears in the Data Bar.

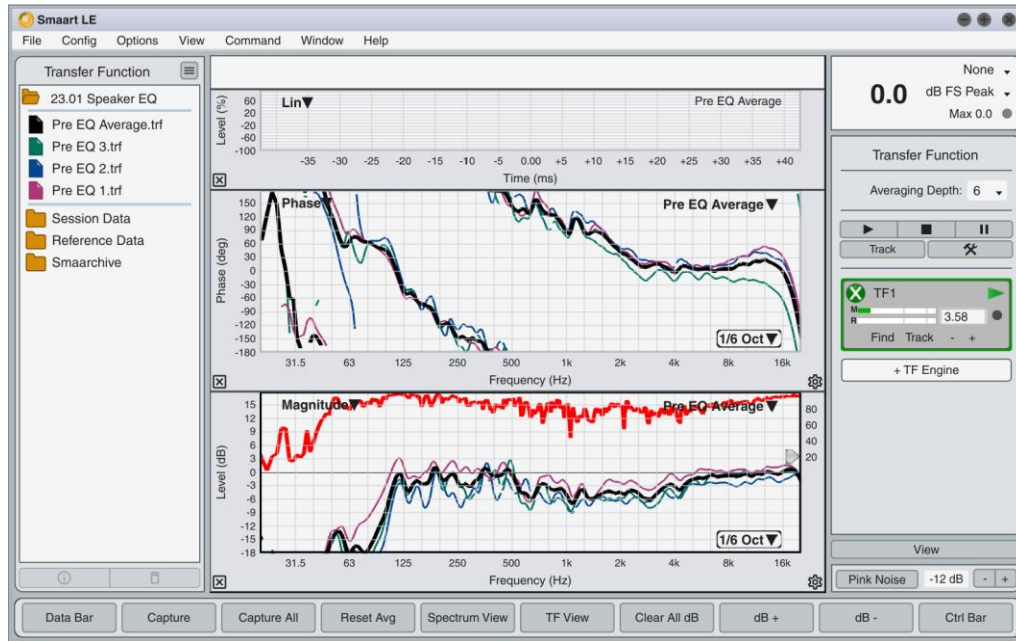

Figure 78 - Spatial Average in black

Considering the average response, we may wish to use a gentle high shelf filter to neutralize the rising magnitude response above 2 kHz and create a more pleasing tonality for the loudspeaker. We can use Smart's locked cursor functionality to determine the appropriate gain reduction that the filter should supply. If we want to know the dB rise from 2 kHz to 16 kHz, we can place our cursor at 2 kHz and then [Ctrl/Cmd] + click to set a locked cursor, then slide our cursor up to 16 kHz.

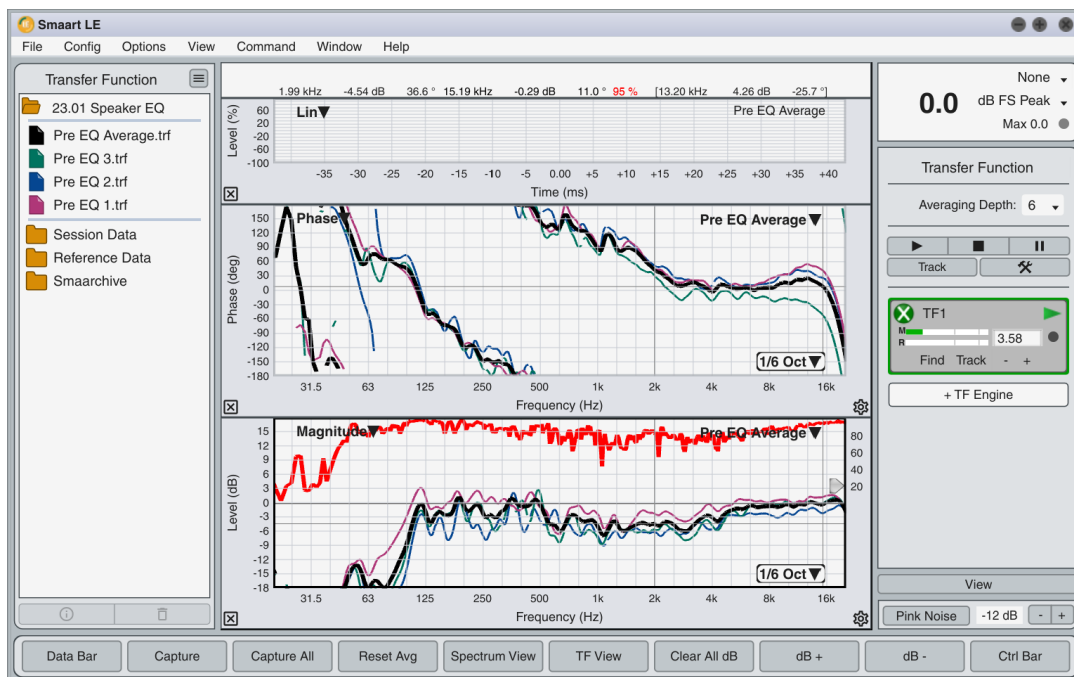

Figure 79 - Using the locked and free cursors to view the amount of rise in the magnitude response between 2 kHz and 16 kHz

The differential cursor readout inside the brackets tells us that the level difference between the two cursor locations is 4.26 dB, so we will start by setting our EQ to a high shelf filter at 2 kHz with a gain reduction of about 4.5 dB.

To observe the change in response, we unhide the measurement engine by clicking the colored circle, start our generator and acquire a new measurement.

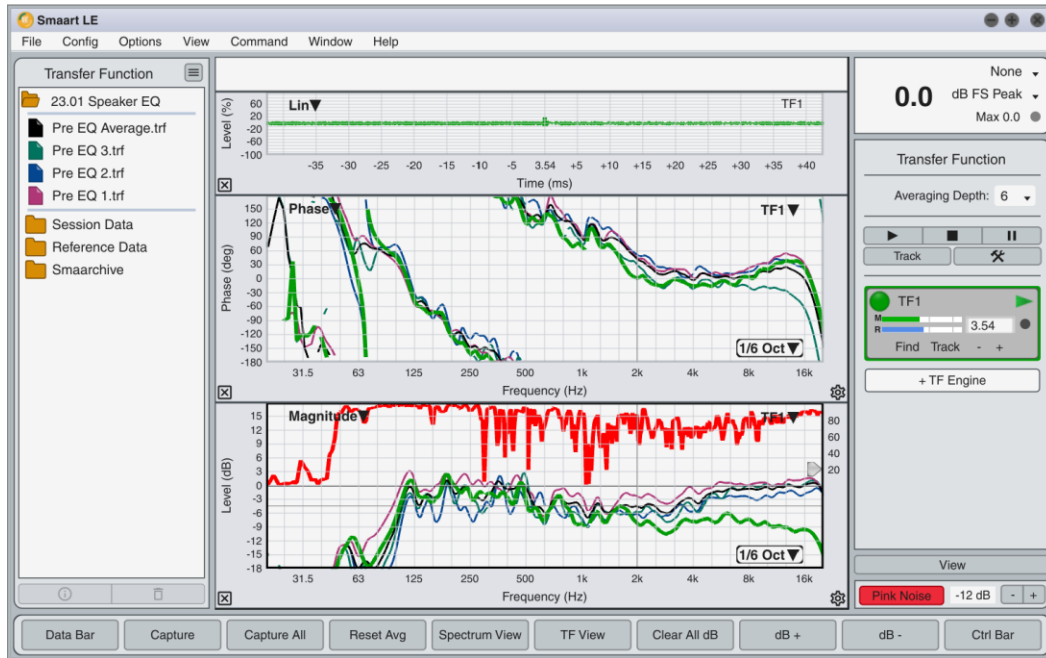

Figure 80 - Observing the effects of the high shelf filter

If we are happy with the resulting response, we can capture the trace as Post EQ 1 and continue onto the next task. Otherwise, we can keep adjusting the EQ until the desired response is obtained.

For informational purposes, we can directly measure the response of the EQ filters to confirm that they are a good match for the response we are attempting to correct. To do this, we can use the output of the equalizer / processor as our measurement signal, such that the measurement loop includes only the processor itself. Readjusting the preamp gain may be necessary, unless you are using an IO device with enough inputs to connect the EQ output while leaving your microphone connected. In this case, you can create a second transfer function engine to compare the DSP output against the loopback signal.

The EQ's response can be viewed alongside the Pre EQ average and the Post EQ stored traces to observe the relationship.

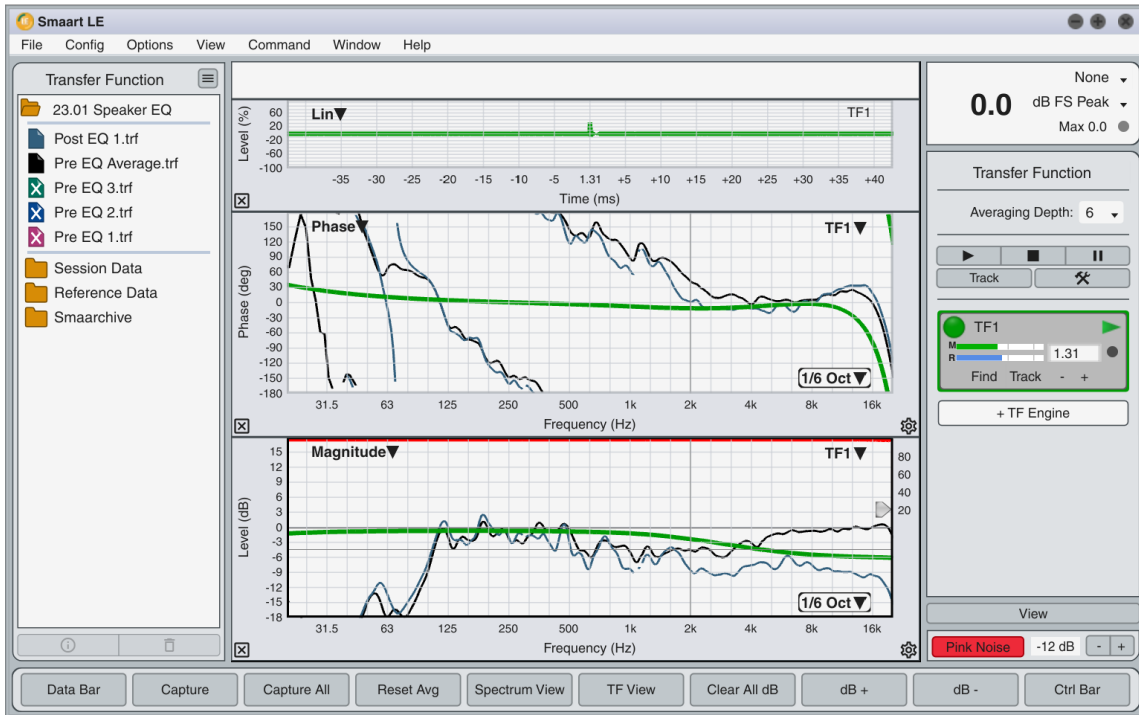

Figure 81 - Comparing the EQ response to the Pre and Post loudspeaker response

To make this more visually straightforward, we will double click the transfer function engine to open the measurement config flyout, and check the *Invert Magnitude Display* option. This allows us to easily confirm that the filter's response curve is a good fit to counteract the rising magnitude response of the loudspeaker at high frequencies.



Figure 82 - Viewing the inverted EQ response compared to the Pre and Post loudspeaker response traces

## OBSERVING NEAR FIELD VS FAR FIELD RESPONSE

In this exercise, we will measure a loudspeaker's response in the nearfield, where the measurement will have a high direct:reverberant ratio, and then measure again further back in the space to observe the effects of the acoustic environment.

We have configured our Smart rig the same way as in the previous example, and started a new session folder for the captured data. Once signal acquisition has been verified and a transfer function measurement created (see previous example), we are ready to begin by placing our measurement mic in the nearfield of the loudspeaker, starting the generator and the transfer function measurement engine running, and then setting our measurement delay using the Delay Finder or Delay Tracker. The measurement is acquired, captured, and named 1 NEAR.

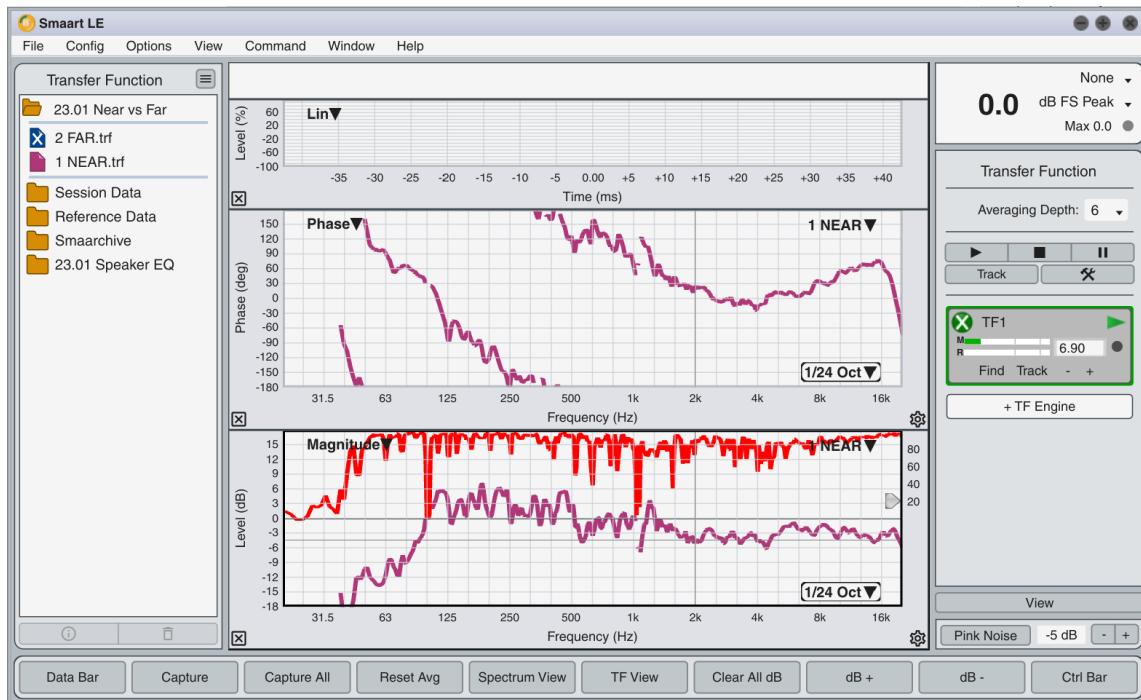

Figure 83 - Nearfield measurement

Note the relatively high overall coherence, as one would expect from favorable measurement conditions. Now we move our microphone further back into the acoustic environment and measure again to observe the change, making sure to properly reset the measurement delay time.



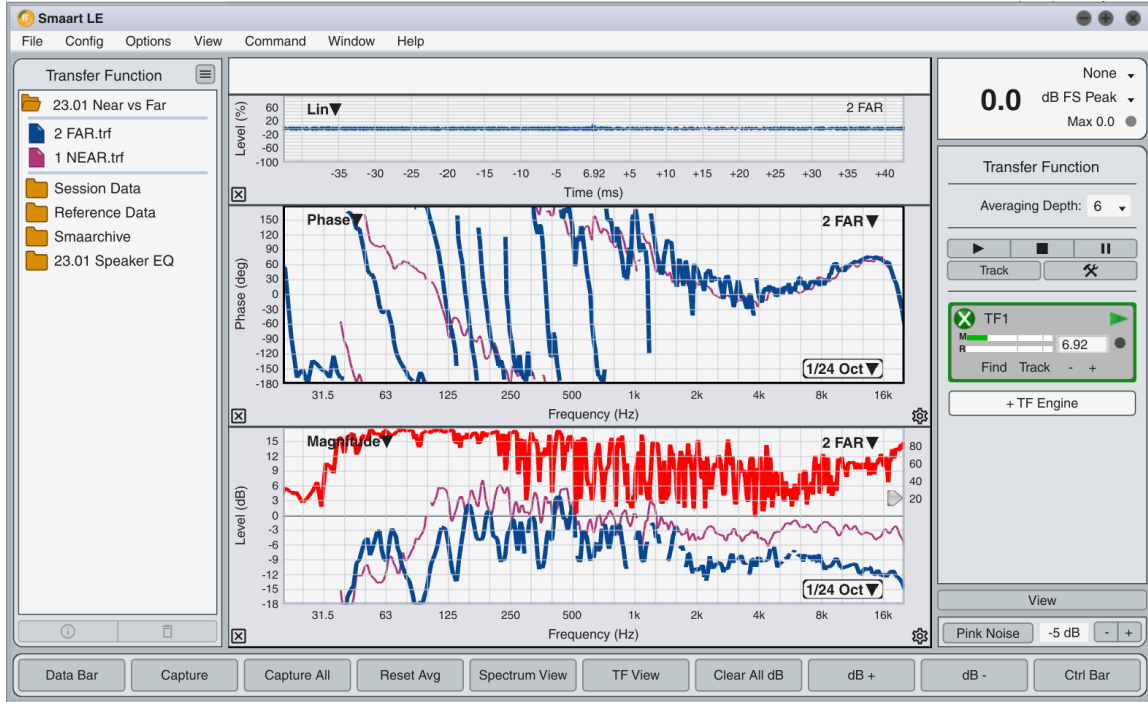

Figure 84 - Far Field measurement

Our new measurement, stored as 2 FAR, shows a broadband level reduction as we would expect from moving farther from an acoustic source. In addition it shows a drop in coherence due to the decrease in direct:reverberant ratio. In addition, the influence of the room is obvious, especially at low frequencies, where our loudspeaker has poor directivity. This is evidenced by the greatly increased micro-ripple in the magnitude and phase traces, and the step downward wraps in the phase trace indicating late-arriving energy.

We can easily and directly characterize the level loss by using the dB + and dB – buttons in the command bar to apply a trace offset to the 2 FAR trace until it overlays the 1 NEAR trace, and then reading the resulting dB offset value from the upper right corner of the magnitude plot.

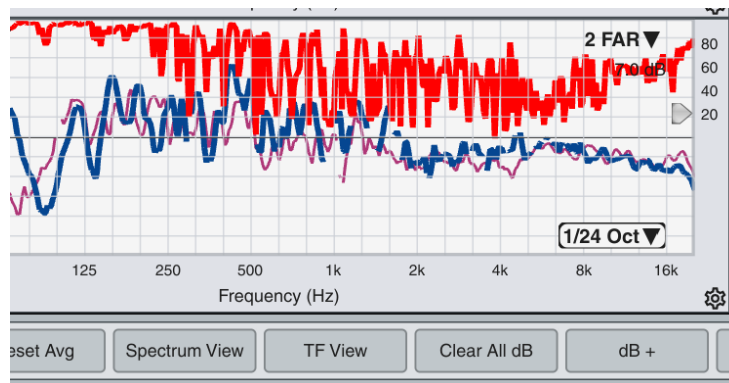

Figure 85 - a trace offset of 7.0 dB

## APPENDIX A: FURTHER READING

Ballou, Glenn. ed. *Handbook for Sound Engineers*. Focal Press.

Beranek, Leo J. *Music, Acoustics and Architecture*. Wiley.

Berg, Richard E. & Stork, David G. *The Physics of Sound*. Prentice Hall.

Borden, G. J. & Harris, K. S. *Speech Science Primer: Physiology, Acoustics and Perception of Speech*. Williams and Wilkins.

Davis, D., Patronis, E., & Brown, P. *Sound System Engineering 4e*. Taylor and Francis.

Everest, F. Alton. *Master Handbook of Acoustics*. Focal Press.

Jones, D.S. *Acoustics and Electromagnetic Waves*. Clarendon Press.

Kleppe, J.A. *Engineering Applications of Acoustics*. Artech House.

Lawrence, Michael. *Between the Lines: Concepts in Sound System Design and Alignment*. Precision Audio Press.

McCarthy, Bob. *Sound Systems: Design and Optimization: Modern Techniques and Tools for Sound System Design and Alignment*. Focal Press.

Olson, Harry F. *Modern Sound Reproduction*. Van Nostrand Reinhold.

Rigden, John. *Physics and the Sound of Music*. Wiley.

Rossi, Mario. *Acoustics and Electro-acoustics*. Artech House.

Toole, Floyd. *Sound Reproduction, Loudspeakers and Rooms*. Focal Press.

## APPENDIX B: BOUNDARY EFFECTS

### ACOUSTICALLY SMALL SOURCES

Acoustically small sound sources are sources whose dimensions are small compared with the wavelengths they produce. Away from boundaries, acoustically small sources tend to be omnidirectional.

A single-driver 1m cube subwoofer would be a good example of an acoustically small sound source as its size would be less than a quarter of the wavelength at low bass frequencies. At 80Hz, for instance, the wavelength would be just over 14 ft (~4m).

The effective directivity of an acoustically small source tends to be governed by local boundaries. The illustration shows a large room with some identical, acoustically small (red spherical) sources in various positions with respect to the room boundaries. (Ignore Victor. He's only there to avoid 3-D ambiguity.)

- The source that is dangling in free space has a Directivity Factor (Q) of 1 and radiates its acoustic power spherically – into full space.
- The mid-floor source (Q=2) has its acoustic power concentrated into a hemisphere. It radiates the same power but concentrated into half-space.
- The baseboard source (Q=4) has its acoustic power concentrated into a quarter-sphere. Again, it radiates the same power but, this time, concentrated, into quarter space.
- And the rear corner source (Q=8) has its acoustic power concentrated into an eighth-sphere – radiating the same power but, this time, concentrated, into eighth space.

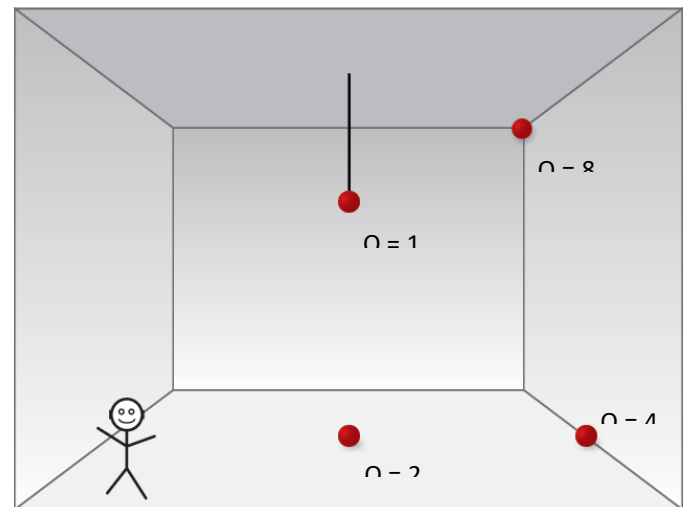

Useful on-axis free field sound pressure level/headroom increases, with respect to  $Q=1$ , will approach 6dB per boundary:

- +6dB for  $Q=2$  (half space)
- +12dB for  $Q=4$  (quarter space)
- +18dB for  $Q=8$  (eighth space)

### MICROPHONES NEAR BOUNDARIES

Similar SPL increases apply to pressure microphones if they are placed acoustically close to a surface – i.e., much less than  $1/6^{\text{th}}$  of the shortest wavelength of interest. At  $1/6^{\text{th}}$  wavelength, the “round trip” will be  $1/3^{\text{rd}}$  wavelength, causing a  $120^\circ$  phase shift and resulting in unity gain summation. Larger spacing would cause partial or full cancellation and combing.

Placing a microphone capsule on the center of a large surface can be useful when measuring, for instance, PA systems in an empty room devoid of seats, as the reflective qualities of the floor will only be visible as a 6dB increase in overall level.



Placement of the microphone in relationship to the floor is critical in this type of measurement, as the reflection from the floor still causes a comb filter. The object of the exercise is make the path of the first reflection so short, relative to the path of direct sound, as to push first null in the resulting comb filter well above the audible spectrum. If the path of the floor bounce is more than a few millimeters longer than the path of direct sound, the first null of resulting comb filter will be low enough to produce at least a visible lowpass filter function in the top octave, if not an actual null within the audible spectrum.

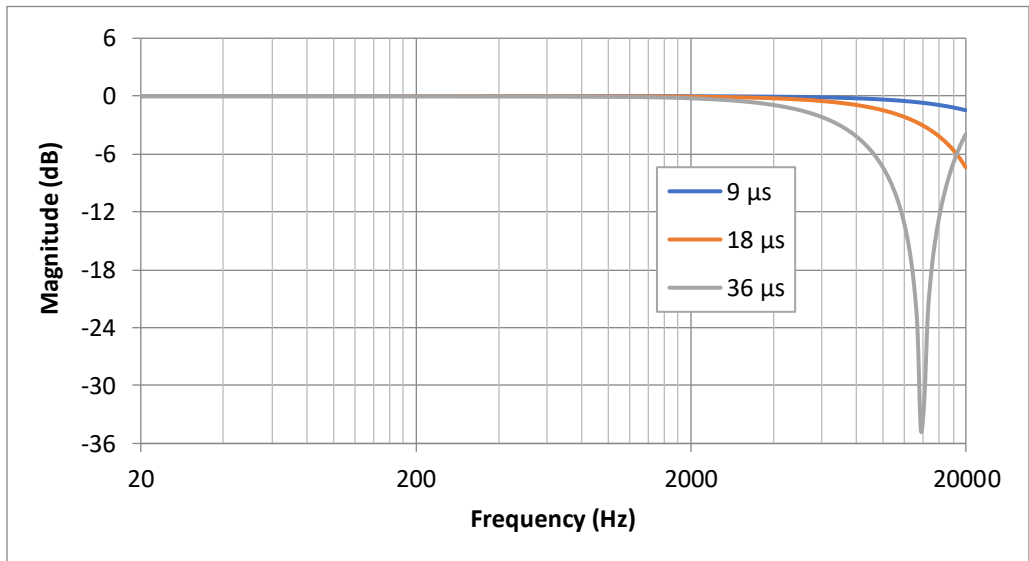

The chart above shows comb filter functions for 9, 18 and 36 μs reflections respectively, which would equate to reflected path lengths approximately one eighth, one quarter and one half inch (3, 6, and 12 mm) longer than the path of direct sound. A common strategy for minimizing this issue is to rest the barrel of the microphone on a coil of cable so that the capsule is actually in contact with the floor or very nearly so. It may also be preferable to use a small diaphragm microphone to further limit the maximum possible length of the floor bounce path.

## APPENDIX C: TYPICAL MEASUREMENT RIG SET-UP

The following are some example measurement-system setup diagrams for transfer function and dual-channel IR measurement in Smaart. Dual-channel measurements are made by comparing a *reference signal* (system input) and a *measurement signal* (system output). They are an essential tool for aligning loudspeaker systems because unlike “time-blind” single-channel RTA measurements, dual-channel measurements can show you both the magnitude and phase response of a system – that is, both energy and timing. Additionally, the same pair of signals (reference and measurement) can be used to calculate the coherence function, an assessment of the linearity of a system that can provide important clues about signal-to-noise ratio, reverberance and overall quality of your measurement data.

### STEREO (2X2) AUDIO I-O

In this example, Smaart’s internal signal generator is used to excite the system under test. The signal generator is assigned to output 1 of a 2-in/2-out audio input-output (I-O) device, labeled *Stereo Audio I-O* in the diagram below. The audio I-O device is connected to the computer via USB or Firewire. Output 1 on the audio I-O is connected to the input of the system under test and also routed back to input 1 on the audio I-O using a Y-split cable (a hard-wired loop-back). Input 1 on the audio I-O will be assigned as the reference signal of a transfer function measurement in Smaart. A measurement microphone connected to input 2 of the I-O device provides the measurement signal.

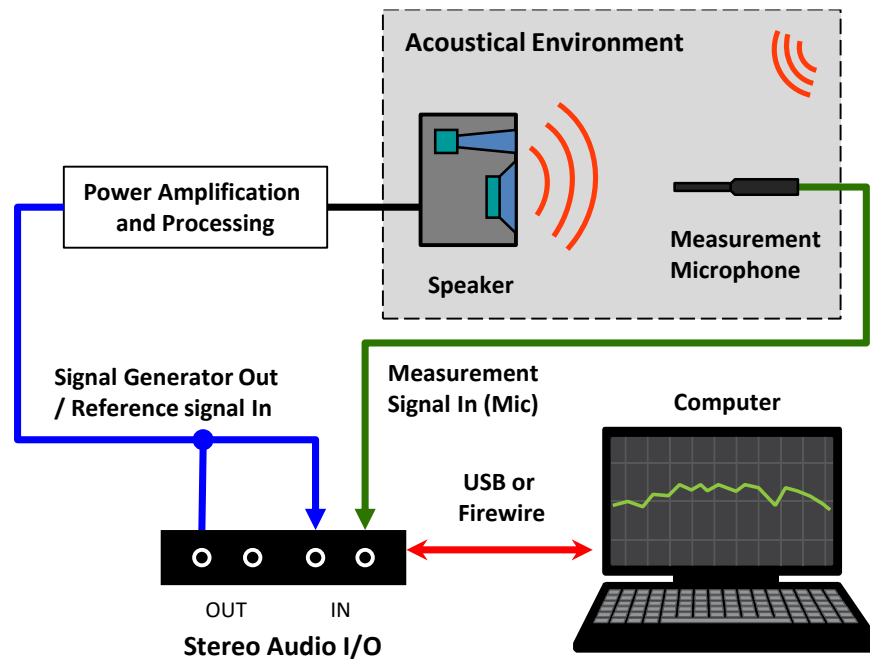

Basic connections and routing should be pretty much the same for any audio I-O device you may encounter. We trust that you understand the audio cabling and connections necessary connect your equipment together. Note that the audio I-O device in this case could conceivably be the computer’s built-in stereo line input and headphone output, in conjunction with a self-powered measurement microphone or external mic preamp and phantom power supply and a little bit of creative cabling.

## MULTI-CHANNEL I-O

In version 7, Smart introduced the capability to run and display as many simultaneous real-time spectrum and transfer function measurements as your computer can handle. Having a multi-channel I-O device enables you to set up multiple microphones to compare different measurement positions in real time, without a lot of running around. This can be a huge advantage when working with larger, more complex sound systems.

### TRADITIONAL USB/FIREWIRE STAND-ALONE INTERFACES

Eight-channel, single rack space packages are a common form factor for multi-channel audio interfaces. The single rack space format makes portability in a rack case, or in your backpack, equally viable. In addition to fielding more microphones, having more audio inputs to the computer enables you to tap into multiple electronic measurement points in a system.

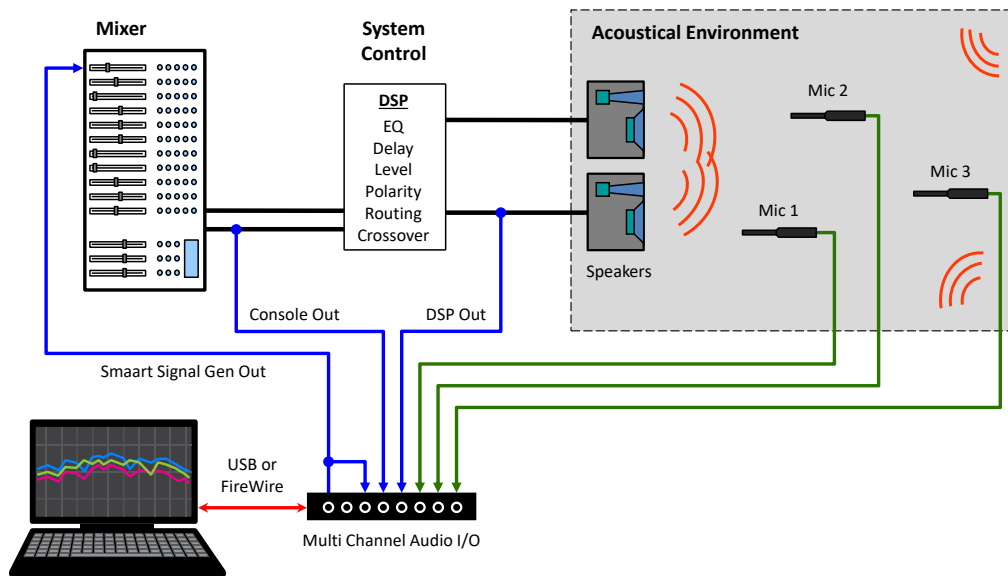

In the diagram above, we have three measurement microphones set up, along with electronic measurement points pre-system-processing and pre-loudspeaker-system. There is also a hard-wired loopback pre-console. The *Console Out* and *DSP Out* can be used as reference signals that let you isolate the response of the system post-console or post-DSP. Alternatively, they can be used as measurement signals for analyzing the console, EQ, or crossover response in Smart.

### NETWORK AUDIO I-O

The ability to digitize an audio system from end-to-end, from stage pre-amps, all the way to the loudspeaker system(s) has become a reality in the past few years. In some professional sound systems, the only analog signals present are those from the microphones to the stage conversion box, where they are digitized and then distributed wherever they are needed via the network.

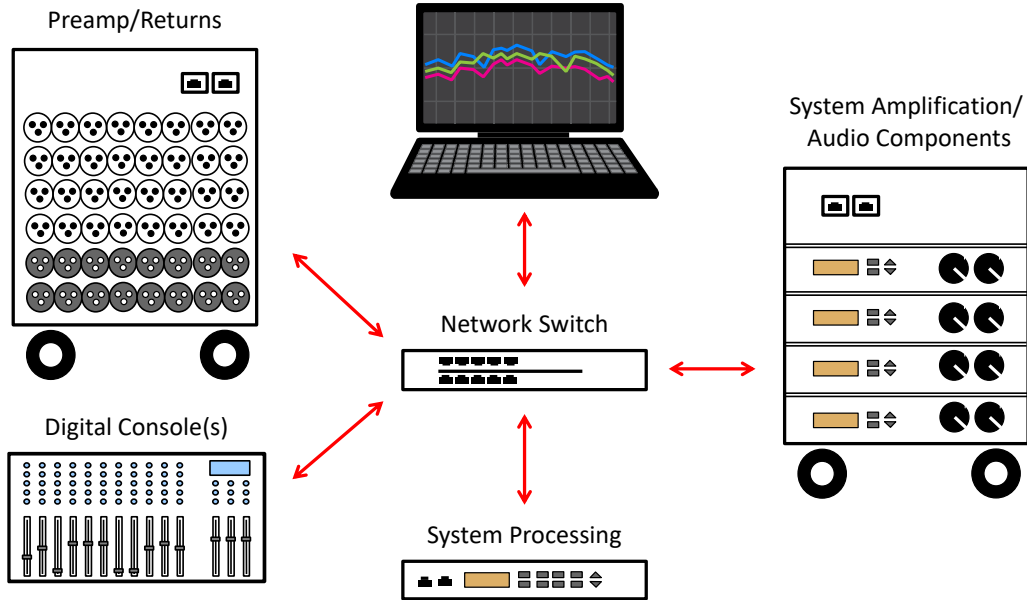

In this scenario, all you might need in terms audio I/O hardware for Smaart is a way to connect your computer to the network. Using the Audinate® Dante® network protocol as an example, a single connection to your computer's Ethernet port makes any signal from any source connected anywhere on the network potentially available for analysis in Smaart and enables you to send test signals from Smaart to any destination on the network that is capable of receiving an input stream. The Dante Virtual Soundcard software application presents a selected group of audio streams from the network to Smaart as a standard, multi-channel ASIO or CoreAudio device. Smaart sees the virtual I-O device, just as it would any locally connected USB or Firewire audio I-O. Selected audio streams from the network appear as input channels on the virtual I-O device and Smaart's signal generator can be assigned to its output channels. Routing is done within the Dante Controller application.

*Audinate and Dante are trademarks of Audinate Pty Ltd.*

## APPENDIX D: TEXT FILE FORMAT FOR ASCII IMPORT

Smaart uses plain ASCII text for importing frequency domain data as microphone calibration curves.

The minimum requirement for importing any type of curve is one frequency value in Hertz and one magnitude value in decibels per line, separated by a tab character – commonly referred to as tab-delimited ASCII text format. Smaart will also ignore blank lines and any line beginning with a semicolon (;) or an asterisk (\*), and so the latter may be used to add comments, headings, or line spaces to help make data files more human-readable.

Tab-Delimited Text		
; Free field Microphone Response		
; Sensitivity: 6.27 mV/Pa @1kHz		
;Freq	→	Mag (dB)
10.00	→	-2.22
10.40	→	-1.90
10.82	→	-1.84
11.26	→	-1.73
11.71	→	-1.51
12.18	→	-1.43
12.68	→	-1.47
13.19	→	-1.28
13.72	→	-1.08
14.27	→	-1.05

*Example of a two-column tab-delimited ASCII text data set. The light blue arrows indicate [Tab] characters. Lines beginning with semicolons [;] will be ignored on import.*

Smaart accepts the ASCII period (a.k.a., point, dot, or full stop) character [.] or comma [,] as the decimal mark, to separate the whole number parts of real numbers from the fractional parts in ASCII import operations. CSV (comma-separated-values) formatted text files is therefore not supported for import. If you wish to import values from a CSV formatted text file, commas used as field delimiters must be replaced with tab characters and quote marks around values (if applicable) must be removed.